AGENDA ITEM SUMMARY / STAFF REPORT
FLORENCE CITY COUNCIL

ITEM NO: 4
Meeting Date: *May 28, 2024*

ITEM TITLE: Resolution PC 24 16 EAP 01
7th & Laurel Castleman Conditional Use Permit Extension Request

OVERVIEW:

Application: An application was submitted on April 26, 2024 requesting extensions for the conditional use permit (CUP) to permit a detached single-unit dwelling (SUD) in Mainstreet Area B (MSB), a temporary CUP for a construction site dwelling, and a variance to allow for a decreased front and rear yard setback.

Resolution PC 23 19 CUP 02 was approved by the Planning Commission on November 14, 2023 and required the final permit inspections on the SUD to be completed within 180 days from the end of the appeal period (May 25th) or the applicant was required to submit an extension request and the associated non-refundable fee. The application for the extension was received prior to this deadline. Since the initial approval the applicant has been working diligently with City of Florence Planning, Building, and Public Works Department to gain required permits and complete this project. Several issues have caused delays in this project completion which are discussed in details in the narrative section of the Findings of Fact. However, the applicant has been in regular contact with City staff and made continuous progress on this project. Planning staff have been in regular contact with the manufacturer of the dwelling to ensure the dwelling purchased when placed will meet the setback requirements. After which, on April 22, 2024 building permit application for the manufactured dwelling was submitted to the building department. Also, the applicant has worked with Public Works staff on the utility locates and applied for right-of-way improvement construction permits. The applicant has also engaged the services of another contractor to assist him in coordination.

Staff Review: Staff reviewed the extension request for the CUP that permitted a detached SUD use in MS, the temporary CUP for the construction site dwelling for the property owner's use, and the variance request. The relevant criteria have been addressed in the Findings.

Process: The application for extension request was submitted April 26, 2024. This extension request is being processed as a Type III Quasi-Judicial review as required by FCC 10-1-1-6-3. Property owner notices of hearing were mailed May 8, 2024 and the property was posted on the same day. A notice of public hearing was published in the Siuslaw Newspaper May 22, 2024. All public noticing requirements have been satisfied.

The findings include a review of the request against the applicable criteria.

Testimony: No public comments were received as of the publishing of the Findings of Facts.

Referrals: Referrals were largely addressed in the initial approval. Due to the adjacent property owner complaints during the initial review, the Florence Police Department and Code Enforcement Officer were sent referral requests on May 16, 2024. At this time comments have not been received.

ISSUES/DECISION POINTS:

Resolution PC 23 19 CUP 02, Condition of Approval 6.1 states the CUP is valid for 1 year from approval; November 14, 2024. However, Condition 6.9 expires on May 25th. Expiration of that condition invalidates the remainder of the resolution and the project is dead.

1. Single Unit Final Inspection Timeline: Consider approving an extension of the CUP granting additional time to place the dwelling structure.
2. Temporary Construction Site dwelling: Consider approving an extension of the temporary CUP for the construction site dwelling that is valid for 3 calendar days following the approved final inspections of the SUD.
3. Setback Variance: Consider approving an extension of the variance for decreased rear and front yard setbacks from 10 feet to 5 feet.

ALTERNATIVES:

1. Approve the extension for PC 23 19 CUP 01 as requested and listed under bullets 1, 2 and 3 above., or
2. Modify the request and approve with modification, or
3. Continue the Public Hearing to a date certain if more information is required, or
4. Approve part of the extension request and deny the rest of the request, or
5. Reject the extension request and request the Findings of Fact be re-written to support denial.

RECOMMENDATION:

Planning Staff— Option 1, Approve extension as requested

AIS PREPARED BY:

Clare Kurth, Associate Planner

ITEM'S ATTACHED:

- “A” Findings of Facts
 - “B” Application and Narrative
 - “C” Site Plan
 - “D” Manufactured Dwelling Permit Applications
 - “E” ROW Permit Application & Invoice
 - “F” Resolution PC 23 19 CUP 02
 - “G” PC 23 19 CUP 02 Approved Findings (*without exhibits*)
 - “H” Email Correspondence with J & M Homes
-

**CITY OF FLORENCE
PLANNING COMMISSION**

RESOLUTION PC 24 16 EAP 01

A REQUEST BY MARION 'BUD' CASTLEMAN FOR AN EXTENSION TO THE APPROVAL OF PC 23 19 CUP 02, A CONDITIONAL USE PERMIT TO CONSTRUCT A SINGLE-UNIT DETACHED DWELLING AT 7TH STREET AND LAUREL STREET IN MAINSTREET AREA B, TEMPORARY CONDITIONAL USE PERMIT FOR A CONSTRUCTION SITE DWELLING, AND A VARIANCE REQUEST TO DECREASE REAR AND FRONT YARD SETBACKS.

WHEREAS, application was made by Marion 'Bud' Castleman, property owner, for an extension of approval PC 23 19 CUP 02; a conditional use permit, temporary conditional use permit, and a variance approval as required by FCC 10-1-1-4, FCC 10-1-1-6-3, FCC 10-4-8, and FCC 10-5; and

WHEREAS, the Planning Commission met in a duly-advertised public hearing on May 28, 2024, as outlined in Florence City Code 10-1-1-6-3, to consider the application, evidence in the record, and testimony received; and

WHEREAS, the Planning Commission of the City of Florence, per FCC 10-1-1-4, FCC 10-1-1-6-3, FCC 10-4, FCC 10-5, and FCC 10-27 finds, based on the Findings of Fact, application, staff recommendation, evidence, and testimony presented to them, that the application meets the applicable criteria through compliance with certain Conditions of Approval.

NOW THEREFORE BE IT RESOLVED that the Planning Commission of the City of Florence finds, based on the Findings of Fact and the evidence in record that:

The request for the extension of PC 23 19 CUP 02, a conditional use permit allowing a single unit dwelling in Mainstreet District A, a temporary conditional use permit for a construction site dwelling and a variance request decreasing the front yard setback from 10 feet to 5 feet to allow for a covered front porch as presented, meets or can meet applicable City codes and requirements, provided that the following conditions of approval are met.

Conditions of Approval:

Approval shall be shown on conditions of approval as supported by the following record:

"A"	Findings of Fact
"B"	Application and Narrative
"C"	Site Plan
"D"	Manufactured Dwelling Permit Applications
"E"	ROW Permit Application & Invoice

“F”	Resolution PC 23 19 CUP 02
“G”	PC 23 19 CUP 02 Approved Findings (<i>without exhibits</i>)
“H”	Email Correspondence with J & M Homes

Findings of Fact attached as Exhibit “A” are incorporated by reference and adopted in support of this decision.

1. Any modifications to the approved plans or changes of use, except those changes relating to Building Codes, will require approval by the Community Development Director or Planning Commission/Design Review Board.
2. Regardless of the content of material presented, including application text and exhibits, staff reports, testimony and/or discussions, the applicant agrees to comply with all regulations and requirements of the Florence City Code which are current on this date, EXCEPT where variance or deviation from such regulations and requirements has been specifically approved by formal Planning Commission action as documented by the records of this decision and/or the associated Conditions of Approval. The applicant shall submit to the Community Development Department a signed “Agreement of Acceptance” of all conditions of approval prior to issuance of a building permit.
3. The applicant shall abide by the conditions of approval of Resolution PC 23 19 CUP 02.
4. This is a one-time extension of approval for the CUP approving the SUD use in MSB shall expire May 28, 2025.
5. This one-time extension of approval for the variance for the decreased front and rear yard setback from 10 feet to 5 feet shall expire November 14, 2024.

ADOPTED BY THE FLORENCE PLANNING COMMISSION/DESIGN REVIEW BOARD the 28th day of May 2024.

Sandra Young, Chairperson
Florence Planning Commission

DATE

**(Proposed) FINDINGS OF FACT
FLORENCE PLANNING COMMISSION
Exhibit "A"**

Public Hearing Date: May 28, 2024 **Planner:** Clare Kurth
Application: PC 24 16 EAP 01

I. PROPOSAL DESCRIPTION

Proposal: A request for an extension of Resolution PC 23 19 CUP 02, a conditional use permits to construct a single-unit detached dwelling in Mainstreet Area B, a temporary construction site dwelling, and a variance request for a decreased front yard setback to allow for a covered front porch and a decreased rear yard setback.

Applicant: Marion 'Bud' Castleman

Property Owners: Marion 'Bud' Castleman

Location: 7th Street and Laurel Street

Site: Map # 18-12-27-44 Tax lot 05602 and 05601

Comprehensive Plan Map Designation: Main Street Area B (MSB)

Zone Map Classification: Downtown

Surrounding Land Use / Zoning:

Site: Undeveloped / Main Street Area B (MSB)
North: Single-Unit Dwelling & Utility Facility / High Density Residential (HDR)
South: Single-Unit Dwelling / MSB
East: Office Building & Single-Unit Detached Dwelling / MSB
West: Single-Unit Detached Dwelling / HDR

Streets / Classification:

East – none / alley; North – 7th Street / Local; West – Laurel Street / Local; South – none

II. NARRATIVE:

On November 14, 2023 the Planning Commission conditionally approved 3 separate items related to the request for approval of a detached single unit dwelling (SUD) in the Mainstreet District B (MSB). The three approvals were 1) the conditional use permit (CUP) to permit the SUD in MSB as required by [Florence City Code \(FCC\) 10-27-3](#), 2) a temporary conditional use permit to allow a construction site dwelling as regulated by FCC 10-4-12-E-3, and 3) a variance request to permit a decreased front yard setback to 5 feet for a covered front porch and a decreased rear yard setback for the covered parking in accordance with [FCC 10-5](#).

In accordance with FCC 10-5-7 and FCC 10-4-8-A, a variance approval and a conditional use permit are valid for 1 calendar year and may apply for a one-time 1 year extension. Under typical circumstance these approvals would be valid until November 14, 2024. The Planning Commission included a condition of approval requiring application for an extension if the final inspection was not completed within 180 days from the end of the appeal period (May 25th). The written request for extension and the non-refundable application fee were submitted to the City Community Development Department on April 26, 2024. This condition and the timelines associated with the variance and the temporary CUP approval will be discussed in more detail under section FCC 10-4-8-A below.

At this time, the manufactured SUD has not been installed and the final inspection has not been completed. Continuous efforts have been made by the applicant to complete this project, but has had unforeseen complications including the ice storm in February 2024 that closed Hwy 126 for several days and continued supply chain shortages and construction delays.

Resolution PC 23 19 CUP 02 included a variance to decreased the front and rear yard setbacks from 10 to 5 feet to allow for a front porch and the required covered parking. The Planning Commission approved the variance in accordance with criteria in FCC 10-5-4-C and determined that a variance was the minimum necessary to address special or unique circumstances related to the subject site. Due to the site constraints, additional time was required to problem solve manufactured dwelling floor plans and models that would fit on the site without requiring a landing that encroaches into side yard setbacks or the required parking areas.

Since the November 14, 2024 approval, the applicant has submitted a work in the ROW permit, a plumbing permit application, building permits for the manufactured dwelling, and been in frequent contact with City staff regarding the progress of this project. The manufactured dwelling plans are currently under review by the City's Building Department and are anticipated to be ready for issuance as early as the week on May 27th. The applicant is seeking approval for an extension to complete this project. The extension approval will allow for completion of the building permit application materials and the approximately 6 to 8 weeks estimated to construct the manufactured dwelling after the building permits are issued. This 6 to 8 week timeline was provided by Doug Adams from J & M Homes that has been working with the applicant.

III. NOTICES & REFERRALS:

Notice: On May 8, 2024, notice was mailed to surrounding property owners within 301 feet of the property and a sign was posted on the property on the same date. Notice was also published in the Siuslaw News on May 15, 2024.

As of the writing of these Findings, the City has received no public testimony.

Referrals: Referrals were sent for the original application and were discussed in the Findings of Fact for Resolution PC 23 19 CUP 02. Additional referral requests were sent to the Florence Police Department and the City of Florence Code Enforcement Office on May 16, 2024.

Police Department & Code Enforcement: As of the writing of these Findings a response to the referral request has not been received.

IV. APPLICABLE REVIEW CRITERIA

Florence City Code, Title 10:

(accessed at: <http://www.ci.florence.or.us/council/title-10-zoning-regulations>)

Chapter 1: Zoning Administration, Sections 1-1-6-3

Chapter 4: Conditional Uses, Section 10-4-8

Chapter 5: Zoning Adjustments and Variances, Section 7

V. FINDINGS

FLORENCE CITY CODE

TITLE 10: CHAPTER 1: ZONING ADMINISTRATION

10-1-1-6-3: TYPE III REVIEWS – QUASI-JUDICIAL LAND USE HEARINGS:

A. Hearings are required for Type III (quasi-judicial) land use matters requiring Planning Commission review. Type III applications include, but are not limited to:

[...]

7. Conditional Use Permits.

[...]

This CUP application has been processed as a Type III quasi-judicial review because such review is not allowable under an administrative Type II procedure. This criterion is met.

B. Notification of Hearing:

- 1. At least twenty (20) days prior to a Type III (quasi-judicial) hearing, notice of hearing shall be posted on the subject property and shall be provided to the applicant and to all owners of record of property within 100 feet of the subject property, except in the case of hearings for Conditional Use Permits, Variance, Planned Unit Development and Zone Change, which notice shall be sent to all owners of record of property within 300 feet of the subject property.**
- 2. Prior to a Type III (quasi-judicial) hearing, notice shall be published one (1) time in a newspaper of general circulation. The newspaper's affidavit of publication of the notice shall be made part of the administrative record.**

Notice of the public hearing was mailed to property owners within 301 feet and posted on the subject property on May 8, 2024. Notice was also published within the Siuslaw News one time on May 15, 2024. These criteria are met.

C. Notice Mailed to Surrounding Property Owners - Information provided:

- 1. The notice shall:**

- a. Explain the nature of the application and the proposed use or uses which could be authorized;
- b. List the applicable criteria from the ordinance and the plan that apply to the application at issue;
- c. Set forth the street address or other easily understood geographical reference to the subject property;
- d. State the date, time and location of the hearing;
- e. State that failure of an issue to be raised in a hearing, in person or by letter, or failure to provide sufficient specificity to afford the decision maker an opportunity to respond to the issue precludes further appeal based on that issue;
- f. State that application and applicable criteria are available for inspection at no cost and will be provided at reasonable cost;
- g. State that a copy of the staff report will be available for inspection at no cost at least 7 days prior to the hearing and will be provided at reasonable cost;
- h. Include a general explanation of the requirements for submission of testimony and the procedure for conduct of hearings.
- i. Include the name of a local government representative to contact and the telephone number where additional information may be obtained.

The provided notice contained all information listed in FCC 10-1-1-6-3-C. These criteria are met.

D. Hearing Procedure: All Type III hearings shall conform to the procedures of Florence City Code Title 2, Chapters 3 and 10.

E. Action by the Planning Commission:

1. At the public hearing, the Planning Commission shall receive all evidence deemed relevant to the issue. It shall then set forth in the record what it found to be the facts supported by reliable, probative and substantive evidence.
2. Conclusions drawn from the facts shall state whether the ordinance requirements were met, whether the Comprehensive Plan was complied with and whether the requirements of the State law were met.

[...]

4. There is no duty upon the Planning Commission to elicit or require evidence. The burden to provide evidence to support the application is upon the applicant. If the Planning Commission determines there is not sufficient evidence supporting the major requirements, then the burden has not been met and approval shall be denied.

The Planning Commission held a public hearing on May 28, 2024 which met the standards of FCC 2-3 and FCC 2-10. The Planning Commission received all materials provided by the applicant. The Findings (Exhibit A) state whether the application criteria were met or not. These criteria are met.

TITLE 10: CHAPTER 4: CONDITIONAL USE PERMITS

10-4-8: EXPIRATION OF CONDITIONAL USE PERMIT:

- A. Authorization of a conditional use permit shall be void one (1) year after the date of approval of a conditional use application, unless a building permit has been issued and substantial construction pursuant thereto has taken place. Substantial construction shall be considered to be completion of a building foundation.**

The applicant may apply to the Planning Commission for a one-time extension of one (1) year maximum duration based on compliance with the following criteria:

- 1. The request for an extension is made in writing prior to expiration of the original approval.**

Per Resolution PC 23 19 CUP 02, Condition of Approval 6.9:

6.9 The construction and installation of the manufactured home and approved final inspections shall be completed within 180 days from the end of the appeal period. If construction is not completed within 180 days from the end of the appeal period then application for an extension shall be submitted in writing in accordance with FCC 10-4-8-A.

180 days from the end of the appeal period was May 25, 2024. The written request for extension and non-refundable application fee was received before this date on April 26, 2024.

In accordance with Resolution PC 23 19 CUP 02, Condition of Approval 6.1 and FCC 10-4-8-A, the authorization for CUP permitting the SUD in MSB is valid for 1 year from approval.

6.1 Authorization of a conditional use permit shall be void one (1) year after the date of approval, November 14, 2024 unless substantial construction has taken place in accordance with requirements of FCC 10-4-8-A (see **Condition 6.9** below for required time line for construction and installation of the dwelling unit).

In accordance with Resolution PC 23 19 CUP 02 the temporary CUP permitting the construction site dwelling expires 3 calendar days following final approved inspection of the primary dwelling.

6.8 In accordance with FCC 10-4-12-E-3-g, the temporary CUP for the construction site dwelling expires 3 calendar days following final inspection approval for the primary dwelling.

As stated in Resolution PC 23 19 CUP 02, Informational 3, the approved variance is valid for 1 year following Planning Commission approval. The variance approval is valid until November 14, 2024.

3. In accordance with FCC 10-5-6-B the variance request shall be valid for 1 year following Planning Commission approval (November 14, 2024) unless substantial construction has taken place or a written request for extension has been submitted to the City Planning Department.

Under typical circumstances this CUP and temporary CUP would not be required to have an extension for 1 year from approval, or November 14, 2024. Due to the circumstance on the subject site at the time of approval, a stricter timeline was applied at the discretion of the Planning Commission. The applicant is requesting a one-time extension for a maximum of 1 year (May 28, 2025) as allowed under this Code section.

In summary, the dwelling was required to be installed and final inspection completed by May 25, 2024 or a written extension request was to be submitted for Planning Commission review. This was more restrictive than the 1 year stated under this Code section. The extension request was submitted prior to the 180 days. This criterion is met.

2. There are special or unusual circumstances that exist which warrant an extension.

Special or unusual circumstances that warrant an extension of Resolution PC 23 19 CUP 02 are:

1. The ice storm in February 2024 that closed Hwy 126 for several days and caused power outages and business closures both locally and in the Willamette Valley.
2. Limited options for manufactured dwellings that will meet the maximum allowed footprint of 15' x 50'.
3. A custom floor plan was required due to the constraints of the lot dimensions beyond the applicants control. The custom floor plan and door placement was required to allow for landings that will not encroach into side yard setbacks or the required onsite parking. [Exhibit D]
4. Correspondence with J & M Homes began in February, 2024 to coordinate on a manufactured home design that would fit the lot. [Exhibit H]
5. There continue to be ongoing supply chain shortages and delays in manufacturing.

Resolution PC 23 19 02 was approved by the City of Florence Planning Commission in a duly noticed public hearing on November 14, 2024.

3. No material changes of surrounding land uses or zoning has occurred.

The City of Florence 2023 Transportation System Plan was adopted October 16, 2023, after the application was deemed received. The changes in the TSP and associated Code updates do not impact the approval of the previous CUP, temporary CUP, or variance approval. With the one exception that minimum driveway width was increased from a minimum of 10 feet to 12 feet.

As such, the applicant shall meet the minimum 12' driveway width in accordance with FCC 10-35-2-12-B. The site plan as submitted and approved at the public hearing on November 14, 2024 proposed a 12-foot driveway. This criterion is met.

B. The discontinuance of a conditional use for twelve (12) consecutive months shall constitute expiration of that conditional use. The use occupying the premises

thereafter shall conform to the regulations of the zoning district in which it is located.

No discontinuance of the CUP or TCUP has occurred for 12 consecutive months. This criterion is met.

TITLE 10: CHAPTER 4: CONDITIONAL USE PERMITS

10-5-7: EXPIRATION OF ADJUSTMENT OR VARIANCE:

- A. Authorization of an adjustment or variance shall expire concurrently with its associated land use approval or one (1) year after the date of approval of an application, whichever is greater, unless a building permit has been issued and substantial construction pursuant thereto has taken place. Substantial construction shall be considered to be completion of a building foundation. The applicant may apply to the Planning Commission for a one-time extension of one (1) year maximum duration based on compliance with the following criteria:**
- 1. The request for an extension is made in writing prior to expiration of the original approval**
 - 2. There are special or unusual circumstances that exist which warrant an extension**
 - 3. No material changes of surrounding land uses or zoning has occurred.**
- B. The Planning Commission may deny the request for an extension of a variance if new land use regulations have been adopted that affect the applicant's proposal. (Ord. 26, 2008)**

As previously discussed under Section FCC 10-4-8-A, the variance request for a decreased front yard setback from 10 feet to 5 feet, to allow for a covered front porch, was valid for one year from approval. The variance approval does not expire until November 14, 2024. New land use regulation were adopted through the 2023 Housing Implementation Plan and the 2023 Transportation System Plan. As previously discussed, the adopted plans do not affect this project as proposed and approved. The Planning Commission, at their discretion may offer the one-time 1 year extension for the variance request at this time. The request is to extend the variance to November 14, 2025.

VI. CONCLUSION – The requested extension meets the requirements of City Code subject to conditions of approval in accordance with Resolution PC 23 19 CUP 02. The variance request and temporary CUP are set to expire November 14, 2024. At the discretion of the Planning Commission, the one-time 1-year extension for the variance request may be extended at this time to be valid through November 14, 2025.

The applicant has met the Code Requirements for an extension for the CUP for the SUD in MSB under section FCC 10-4-8-A and has demonstrated an effort to complete this project. The one-time extension is anticipated to be adequate time to allow for the completion of this project based on timelines provided by the manufacture home dealer, the Building Department, and accounting for the progress made on the project since the initial approval. The following are the proposed

extension dates for each of the 3 approvals granted in association with Resolution PC 23 19 CUP 02:

- CUP permitting the SUD in MSA: a one-time 1 year extension valid through May 28, 2025.
 - Temporary CUP for the construction site dwelling: No change. In accordance with Resolution PC 23 19 CUP 02, Condition of Approval 6.8 the temporary CUP shall remain valid for 3 days following the final approved inspections of the dwelling.
 - Variance request: a one-time 1-year extension valid through November 14, 2025.
-
-

VII. EXHIBITS

"A" Findings of Fact
"B" Application and Extension Request
"C" Site Plan
"D" Application for Manufactured Dwelling Permit
"E" ROW Permit Application & Invoice
"F" Resolution PC 23 19 CUP 02
"G" Approved FOF PC 23 19 CUP 02 (<i>without exhibits</i>)
"H" Email Correspondence with J & M Homes

City of Florence
Building Dept.

Address: 1340 7th St.

EXHIBIT B

Subject: Request for an extension

Due to poor weather the lot prep has been ~~at~~ delayed. I'm working with a loan company and I've been approved. The unit will be built as soon as funds are released and available. During that time the lot prep will continue. I need more time to complete this project.

Best regards,
Marion Costello



Property Description

Site Address: 7th and Laurel Sts.

General Description: SE Corner of 7th and Laurel, 2 legal lots between Laurel and the alley

Assessor's Map No.: _____ - _____ - _____ - _____

Tax lot(s): _____

Zoning District: Mainstreet

Conditions & land uses within 300 feet of the proposed site that is one-acre or larger and within 100 feet of the site that is less than an acre OR add this information to the off-site conditions map

(FCC 10-1-1-4-B-3): _____

Project Description

Square feet of new: < 1,000 sq. ft. SFR

Square feet of existing: 0

Hours of operation: N/A

Existing parking spaces: 0

Is any project phasing anticipated? (Check One): Yes No

Timetable of proposed improvements: Fall 2023

Will there be impacts such as noise, dust, or outdoor storage? Yes No

If yes, please describe: During Construction

Proposal: (Describe the project in detail, what is being proposed, size, objectives, and what is desired by the project. Attach additional sheets as necessary)

Place one new single family manufactured home on one or more lots, pending site plan. East lot is primary--Parcel 2. & temporary mobile building - construction RV

For Office Use Only:

Date Submitted: Aug. 9, 2023

Fee: \$1804.77

Received by: gdfc

Paid

City of Florence Manufactured Home Permit Application

MFH PERMIT #
309-24-000216MD
BUILDING PERMIT #

250 hwy 101 Florence, OR 97439
Building Inspection 541-997-2141
Fax Number: 541-902-2189

Exhibit D

TYPE OF PERMIT				
<input checked="" type="checkbox"/> 1 & 2 Family dwelling or accessory	<input type="checkbox"/> Commercial/Industrial	<input type="checkbox"/> Multi-family	<input checked="" type="checkbox"/> New construction	
<input type="checkbox"/> Addition/alteration/replacement	<input type="checkbox"/> Tenant improvement	<input type="checkbox"/> Fire sprinkler/alarm	<input type="checkbox"/> Plumbing	
<input type="checkbox"/> Demolition	<input type="checkbox"/> Other	<input type="checkbox"/> Mechanical	<input checked="" type="checkbox"/> Manufactured Home	
JOB SITE INFORMATION				
Job address: <u>1340 7th St</u>		/ Impervious Surface %:	All Enclosed Building %:	
Map number:	Tax Lot:	Subdivision:		
Description of work: <u>CONCRETE RUNWAYS FOR MH/ Garage & Flatwork</u> Valuation amount \$ _____				
Cont. <u>AND COMPACTED GRAVEL</u> / Commercial Mechanical Bid or Valuation Amount \$ _____				
OWNER		STAFF-Planning Department		
Name: <u>Marion Castleman</u>		<u>Office Use</u>		
Mailing address: <u>562 HEALOCK ST</u>		Subdivision <u>Chicago Addition to Florence</u>		
City: <u>FLORENCE</u>	State: <u>OR</u>	Lot# _____	Tax Lot # <u>05602</u>	
Ph: <u>541 999 0822</u>	Fax: _____	Map # <u>18-12-27-44</u>	Zone <u>Main STREET / Area B</u>	
APPLICANT		Lot Size In square feet <u>2614</u>		
Name: <u>SAME</u>		Use Permitted In this Zone <input checked="" type="checkbox"/> Yes <input type="checkbox"/> No		
Mailing Address: _____		Historic Review Required <input type="checkbox"/> Yes <input checked="" type="checkbox"/> No		
City: _____	State: _____	Zip: _____	Flood Plain <input type="checkbox"/> Yes <input checked="" type="checkbox"/> No	
Ph: _____	Fax: _____	Cell: _____	Set Backs—Front <u>10</u> Back <u>5</u> Side <u>20</u>	
CONTRACTOR / Installer				
Business name: <u>LOW HOMES</u>				
Address: <u>33213 Highway 34 SE</u>				
City: <u>ALBANY</u>	State: <u>OR</u>	Zip: <u>97322</u>	Side Of Corner Lot <u>5</u> <u>Garage</u>	
Ph: <u>541 465 9449</u>	Fax: <u>541 928 1414</u>	Cell: _____	Airport Zone <input checked="" type="checkbox"/> YES <input type="checkbox"/> No	
CCB number: _____	Florence City Lic. # _____			
MANUFACTURED HOME INSTALLER				
Name: <u>MDI N Line Const</u>				
Address: <u>2029 MDI NUMBER</u>				
City: _____	State: _____	Zip: _____	Notice: All contractors and subcontractors SHALL be licensed with the Oregon Construction Contractors Board under provisions of ORS 701. and Licensed with the CITY OF FLORENCE	
Ph: _____	Fax: _____	Cell: _____		
CCB LIC. # : _____	MDI # : <u>2029</u>			State Highway Involvement <input type="checkbox"/> Yes <input checked="" type="checkbox"/> No
ENGINEER				Special Site or Parking Requirements: Yes <input type="checkbox"/> No <input checked="" type="checkbox"/> IF YES ATTACH COPY TO PLANS
Name: _____				
Address: _____				
City: _____	State: _____	Zip: _____	PLUMBING CONTRACTOR	
Ph: _____	Fax: _____	Cell: _____		
CCB number: _____	Florence City Lic. # _____			Business name: <u>DAVE HARRISON PLUM.</u>
ELECTRICAL CONTRACTOR				Address: _____
Name: _____				
Address: _____				
City: _____	State: _____	Zip: _____	City: <u>FLORENCE</u>	
Ph: _____	Fax: _____	Cell: _____	State: <u>OR</u>	
CCB number: _____	Supervisor #: <u>STAN</u>		Zip: <u>97439</u>	
E-mail: _____	Business name: <u>SIVSLAW ELECTRIC</u>			
I hereby certify I have read and examined this application and the attached checklist. All provisions of laws and ordinances governing this work will be complied with, whether specified herein or not.				
Address: <u>1710 LAUREL WAY</u>				
Authorized signature: <u>Marion Castleman</u>	City: <u>FLORENCE</u>	State: <u>OR</u>	Zip: <u>97439</u>	
Print name <u>Marion Castleman</u>	Date: <u>4/22/24</u>	Ph: <u>997 9921</u>	Fax: _____	
Cell: _____	CCB number: <u># 8689</u>			
Notice: This permit application expires if a permit is not obtained within 180 days after it has been accepted as complete.				

309-24-000216-MD
updated 5/22/24

DREAM SILVER SERIES 14x48 DRM 481M
2 BEDROOM, 1 BATH - 648 SQ. FT.
2024

SINGLE WIDE

4-5-2024

BOTH ENTRY DOORS
ON SAME SIDE
OF MFG HOME

49'-6"
48'-0"

14'-6"

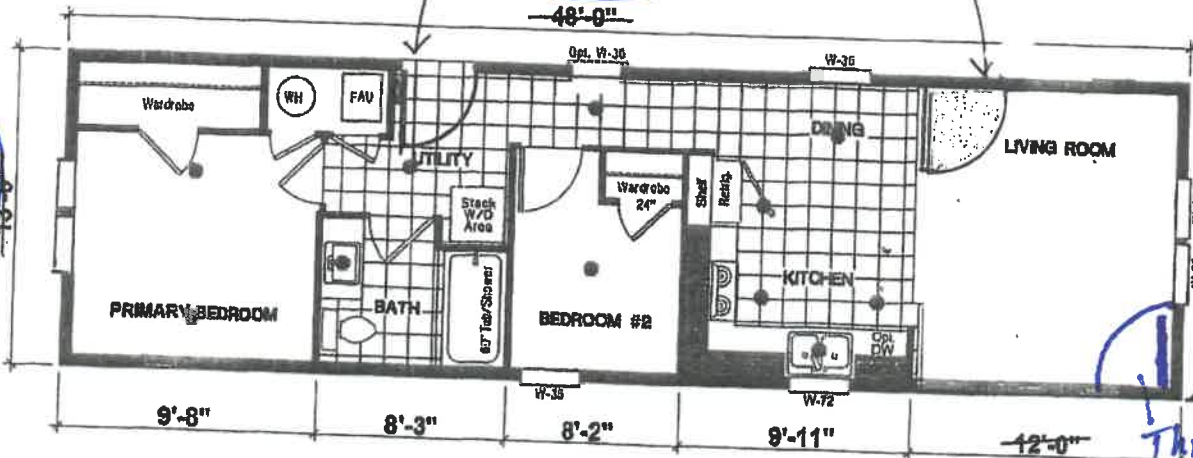

FLIP ENTIRE
FLOOR PLAN
SIDEWAYS!

Third Door SW corner after flipped
behind covered parking on site plan

7th St Alley

LAUREL ST

THIS IS THE FLOOR PLAN FOR 7th LOT
THIS HOME WILL BE BUILT FOR THIS LOT
THE FRONT FACING 7th ST. THE 2
FRONT DOORS FACING 7th ST.
PLAN IS 648 SQ. FT. PLAN IS 15' x 50'
THE HOME IS SOLD BY JIM HOMES OF ALBANY, OR
I'M WORKING WITH DOUG ADAMS 541-405 9448

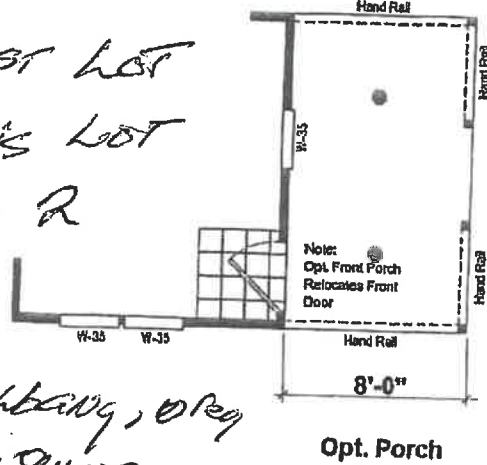

N ↓

7th St



Building Permit

Residential Plumbing

Permit Number: 309-23-000547-PLM

IVR Number: 309073688453

Web Address: www.ci.florence.or.us

Email Address: florencepermits@ci.florence.or.us

Permit Issued: November 28, 2023
Project: Water Meter and Backflow Device

Application Date: November 27, 2023

TYPE OF WORK

Plumbing Specialty Code Edition: 2021

Category of Construction: Manufactured Dwelling

Type of Work: New

Submitted Job Value: \$0.00

Description of Work: Water Meter and Backflow Device. This is for a new manufactured dwelling site.

JOB SITE INFORMATION

Worksite Address

1340 7th ST
FLORENCE OR 97439

Parcel

1812274405602

Owner:

MARION L CASTLEMAN &
JOAN A CARR REV LIV TR

Address:

5170 GRAND AVE SPACE 16
FLORENCE, OR 97439

LICENSED PROFESSIONAL INFORMATION

None Specified

PENDING INSPECTIONS

Inspection

3999 Final Plumbing

Inspection Group

Plumb Res

Inspection Status

Pending

SCHEDULING INSPECTIONS

Various inspections are minimally required on each project and often dependent on the scope of work. Contact the issuing jurisdiction indicated on the permit to determine required inspections for this project.

Schedule or track inspections at www.buildingpermits.oregon.gov

Call or text the word "schedule" to 1-888-299-2821 use IVR number: 309073688453

Schedule using the Oregon ePermitting Inspection App, search "epermitting" in the app store

Permits expire if work is not started within 180 Days of issuance or if work is suspended for 180 Days or longer depending on the issuing agency's policy.

Per R105.7 and R 106.3.1, a copy of the building permit and one set of approved construction documents shall be available for review at the work site.

All provisions of laws and ordinances governing this type of work will be complied with whether specified herein or not. Granting of a permit does not presume to give authority to violate or cancel the provisions of any other state or local law regulating construction or the performance of construction.

ATTENTION: Oregon law requires you to follow rules adopted by the Oregon Utility Notification Center. Those rules are set forth in OAR 952-001-0010 through OAR 952-001-0090. You may obtain copies of the rules by calling the Center at (503) 232-1987.

All persons or entities performing work under this permit are required to be licensed unless exempted by ORS 701.010 (Structural/Mechanical), ORS 479.540 (Electrical), and ORS 693.010-020 (Plumbing).

PERMIT FEES

Fee Description	Quantity	Fee Amount
Backflow preventer	1	\$31.80
Balance of minimum permit fees - plumbing		\$59.88
Sewer Connect Fee	249.71	\$249.71
Water Connect Fee	1050	\$1,050.00
State of Oregon Surcharge -Plumb (12% of applicable fees)		\$11.00
	Total Fees:	\$1,402.39

Note: This may not include all the fees required for this project.

REQUIREMENTS FOR EXCAVATION IN PUBLIC RIGHT OF WAY Contractor's Responsibility

APPLICATION

- *Submit application, with one 8 ½" x 11" site plan, allowing 5 working days prior to proposed dates of excavation.*
- Include plans or dimensioned drawing with application showing how cuts are to be restored and the location of cuts in relation to property lines and streets. Please include cross streets on drawings.
- Obtain ALL appropriate building permits and agreements.
- Once permit is approved and issued:
 - Pay \$45.87 permit fee.
 - Pay \$84 water/sewer line inspection fee (per service).
 - Pay \$95/hour street/curb/sidewalk inspection fee.
 - Pay \$1.72/lineal foot fee for ALL work in the Public right of way.

NOTE: By signature of the applicant on this permit, applicant is financially responsible for the fees unless the City of Florence Public Works Department is notified by the applicant that the job was canceled.

JOBSITE

- Call for locates: 1-800-332-2344
- Call for inspections: 541-997-4106
- Call for inspections of forms before curbs and concrete driveway aprons are poured. No inspections will be given until permit is paid in full. **When calling for inspection, you must use the (1) project address as listed on the permit (NO lot numbers) and (2) leave a contact name and (3) phone number. Inspections will be denied unless all three items appear in the inspection request. If inspection is denied, please call it in again, including all information, for the next working day.**
- All street or alley cuts are to be inspected by a City inspector.
- The following will accompany Contractor's copy of permit if requested:
 1. Typical Street Cross Section (F-201)
 2. Concrete Curbs (F-203)
 3. Sidewalks (F-205)
 4. Concrete driveway aprons and curb cuts (F-208a – F-208b)
 5. Wheelchair ramps (F-206 – F-206a)
- City of Florence Public Works Inspector:
541-997-4106

CERTIFICATE OF INSURANCE REQUIREMENTS

- Certificate MUST be in a business name.
- \$1,000,000 minimum Aggregate Liability Coverage
- City of Florence must be named as certificate holder and "Additional Insured."
- Current certificate must be on file before permit will be issued.
- Certificate may be faxed to the City of Florence Public Works Department at 541-590-4017.

OFFICE USE ONLY
PERMIT NO. _____

**CITY OF FLORENCE PUBLIC WORKS
RIGHT OF WAY EXCAVATION WORK PERMIT**

Applicant (City Approved Contractor) Marion Castleman Const. Inc.

Applicant's Address [Redacted] Florence Phone [Redacted]

Purpose of Excavation: Sewer Water Driveway Curb Cut Sidewalk Other _____

Attention: Oregon law requires you to follow rules adopted by the Oregon Utility Notification Center. Those rules are set forth in OAR 952-001-0010 through OAR 952-001-0090. You may obtain copies of the rules by calling the center. (Note: the Telephone number for the Oregon Utility Notification Center is (503) 232-1987. For locates, call 1-800-332-2344.)

One-Call Center Identification No. (for this project): _____ Planning #: _____

Description of Work: POPP Ground for Driveway Slab

Project Address	Start Date	Completion Date	Surface Type	Total ROW Work
<u>1340 7th St.</u>	<u>Already</u>			

* Asphalt to be patched to grade the same day per Inspector's instructions.
** Street Cuts on Arterials & Collectors will be hot patched the day of the cut.

I agree to comply with all provisions of City of Florence FCC Title 8 Chapter 2 Standards & Specifications for excavating and restoring any Public Improvement, holding the City of Florence harmless from any liability of any kind resulting from or in connection with my/our activities in excavating and restoring any Public Improvement.

X Signed: Marion Castleman Date: April 7/24

Insurance Certificate on file, \$1,000,000.00 blanket coverage endorsed for completed operations through the fast permanent restoration of City Streets.
 Plans Attached W & S Fees Paid **Copies To:** Permittee Public Works Address File

OFFICE USE ONLY		INSPECTOR APPROVAL	
Basic Permit Fee	\$45.87	Comments:	
Lineal foot charge (\$1.72/LF) ALL Right of Way Work	\$		
Inspection Fee \$84 Water/Sewer Line	\$		
Inspection Fee \$95/hr Street/Curb/Sidewalk 1 Hour Minimum	\$		
TOTAL DUE:	\$	Inspection Date	Inspector
		Remarks	

Approval: _____ Date: _____

Contractor Shall Provide

Contractor's License Number and Expiration Date: _____

Contractor's Insurance Company and Policy Number: _____

Amount of Insurance carried by Contractor: _____

Amount of Insurance required by City: _____

Amount of Bonding required by the City – if applicable: _____

Emergency Contact Information: _____

*Contractor must furnish proof of the above before this permit is issued.

Contractor Will Give

1. Notification to Public Work Department of start date of the project.
2. Notification of project inspection during construction.
3. Notification of project completion date.
4. Notification for final inspection and approval.
5. Notification of approval of the project by the City applicant. This information will be sent by the City Recorder, and any deposits will be returned upon satisfactory completion of the project.
6. A set of as-built plans will be given to the City, if applicable.
7. Engineered drawings showing detailed plans for all facilities.
8. Map(s) showing location of all facilities.

THIS PERMIT IS NOT TRANSFERABLE

INSURANCE WAIVER:

I, William Castles agree to save the City, its officials, employees, and agents harmless from any and all costs, damages and liabilities which may accrue or be claimed from any and all costs, damages and liabilities which may accrue or be claimed to accrue by reason of any work performed under this permit. I am also aware of all requirements of Ordinance No. 14, Series 2007.

PENALTIES: On conviction of failure to comply with Ordinance No. 14, Series 2007, a fine not to exceed \$200 for each day violation continues to persist after due notice has been given.

APPROVED BY:

Public Works Director

Date:

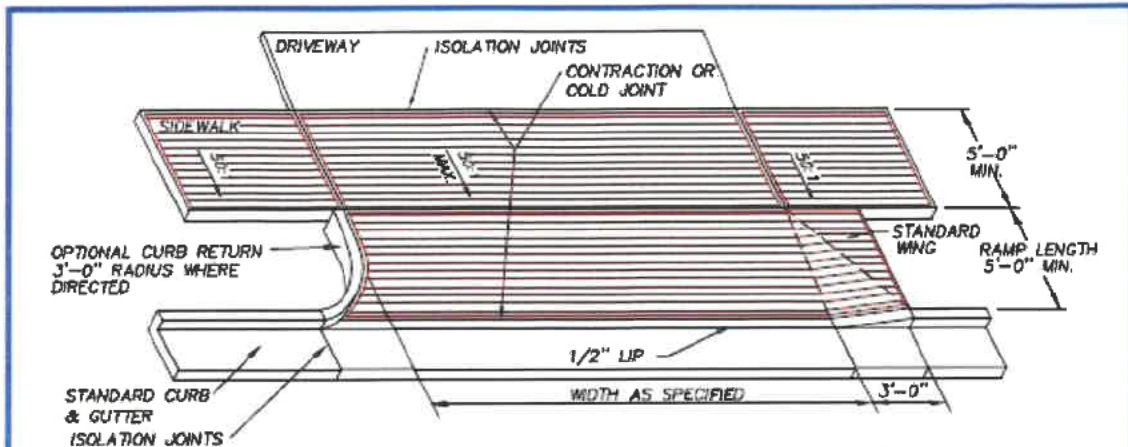

DRIVEWAY / ALLEY APPROACH FOR SET-BACK SIDEWALK

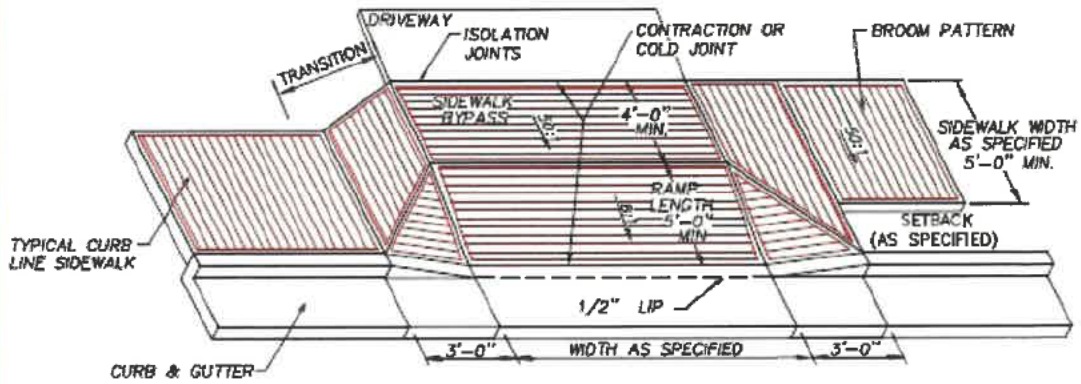

DRIVEWAY / ALLEY APPROACH FOR CURBSIDE & PARTIALLY SET-BACK SIDEWALKS

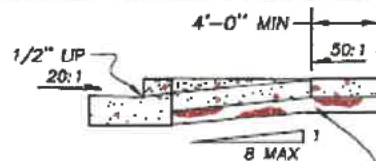

MIN. 2" OF 3/4"-0 CRUSHED AGGREGATE BASE OR CLEAN SELECT NATIVE SAND AS APPROVED.

TYPICAL SECTION THROUGH RAMP

NOTES:

- 1) RESIDENTIAL DRIVEWAYS AND SIDEWALK SECTIONS THROUGH DRIVEWAYS SHALL HAVE A MINIMUM NORMAL THICKNESS OF 6". CONCRETE STRENGTH SHALL BE 3300 PSI.
- 2) CONCRETE FOR COMMERCIAL USE AND ALLEY APPROACHES SHALL HAVE A MINIMUM NOMINAL THICKNESS OF 8". CONCRETE STRENGTH SHALL BE 3300 PSI.
- 3) CURB TRANSITIONS FOR COMMERCIAL USE AND ALLEY APPROACHES SHALL BE 5 FT.
- 4) CONSTRUCT CONTRACTION JOINT IN CENTER OF DRIVEWAY WHEN DRIVEWAY WIDTH EXCEEDS 15'.
- 5) NO LIP AT GUTTER IF USED AS SIDEWALK ACCESS RAMP.
- 6) SEE SIDEWALK DETAILS FOR RESTRICTIONS AND SPECIFICATIONS NOT SHOWN.
- 7) THE 50:1 CROSS-SLOPE OF SIDEWALK IS MEASURED FROM HORIZONTAL. THE 12:1 SLOPE OF SIDEWALK TRANSITION TO DRIVEWAY/ALLEY IS RELATIVE TO THE RUNNING SLOPE OF THE SIDEWALK. THE SLOPE OF THE APRON IS MEASURED RELATIVE TO HORIZONTAL.

**CITY OF FLORENCE
STANDARD DRAWING**

**DRIVEWAY AND ALLEY
APPROACHES FOR
SETBACK OR
BYPASS SIDEWALK**

DATE:
MARCH 2007

DRAWING NO.
F-208A

FILENAME: F-208a.DWG

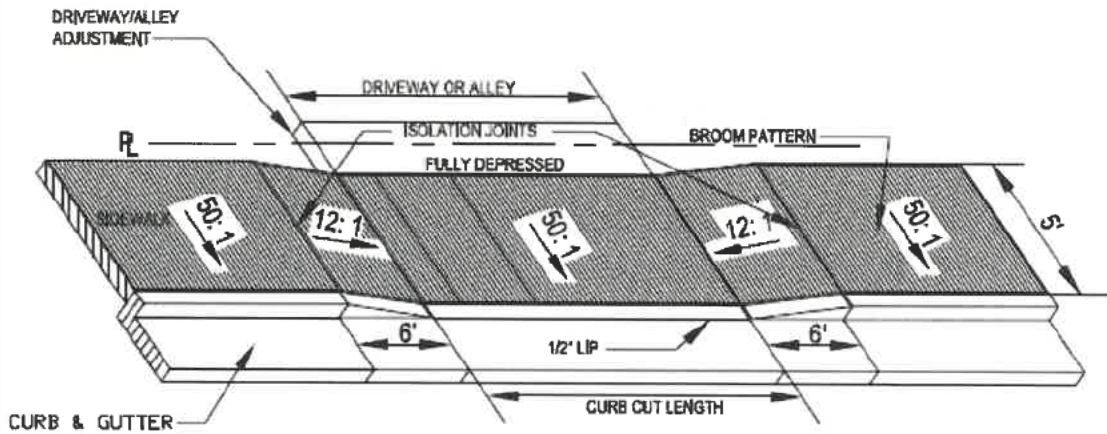

CURBSIDE - SIDEWALK APRON FOR 5' WALKS

SLOPE:

50: 1 (2%)

12: 1 (8%)

NOTES:

1. ALL CONCRETE SHALL BE 6" INCH MINIMUM THICKNESS OF 3,000 psi. FIELD STRENGTH
2. ADD JOINT IN CENTER OF APRON AND CURB & GUTTER WHEN APRON WIDTH EXCEEDS 20' FT.
3. ALL SLOPES ARE RELATIVE TO HORIZONTAL.
4. IF THE APRON WILL ALSO SERVE AS A SIDEWALK ACCESS RAMP IN PLACE OF A STANDARD RAMP, THE APRON SLOPE FROM THE GUTTER TO THE SHALL BE 12: 1 OR LESS WITH NO LIP.

**CITY OF FLORENCE
STANDARD DRAWING**

**DRIVEWAY AND
ALLEY APRON
5' CURBSIDE
SIDEWALK**

DATE:
9-22-11

DRAWING NO.
F-208B

RECEIVED
City of Florence
NOV 22 2023
By: SB

17th St

COPY



Marion Castleman Project 17th St
Grading

CONCRETE
SLAB,
15 X 50'

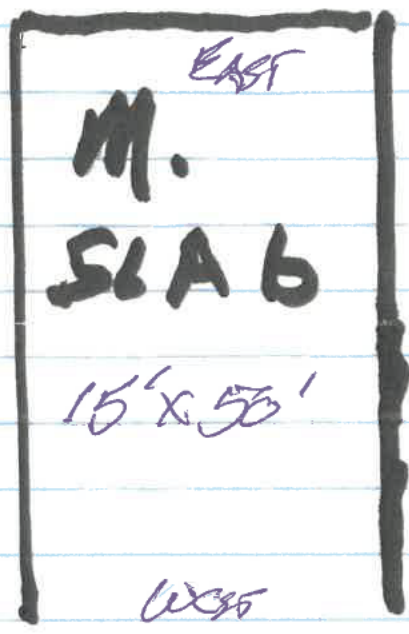

SLAB TO LAY
EAST + WEST

NOT TO
SCALE

EXCAVATED AREA
2" ENHANCED COMPACTED
STEEL SET THEN
POUR CONCRETE

Grading plan for 17th St. LOT #2
Manufactured Home to sit on a
concrete pad approx 15' wide and 50'
long and 6" thick.

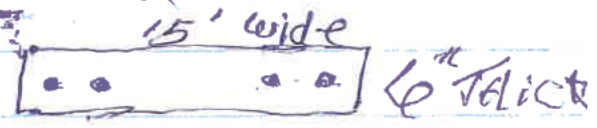

TOP OF SLAB
Below grade that meets City Code

(2) #4 Rebar around perimeter of foundation
slab, once mobil is set in position

(3) 8" Masonry Blocks will be laid in place
as a screed

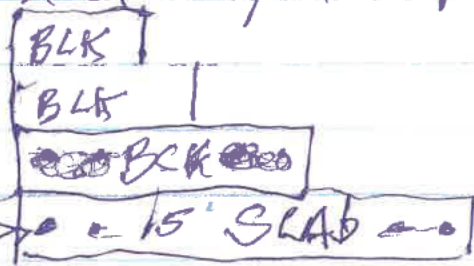

#4
Steel

Jeremy

Duck-Insert

YTD



INVOICE



City of Florence

Public Works
 250 Hwy 101 N
 Florence, OR 97439
 Phone 541-997-4106 Fax 541-590-4017

INVOICE #2024-03
 DATE: 5/23/2024

TO:
 Marion Castleman
 [REDACTED]
 Florence, Oregon 97439

PROJECT NAME:
 Sidewalk extension along 7th Street

P.O. NUMBER	REQUISITIONER	SHIPPED VIA	F.O.B. POINT	TERMS
				30 days

QUANTITY	DESCRIPTION	UNIT PRICE	TOTAL
1	8' wide by 60' long sidewalk along the 7 th Street frontage of tax lot and map #18-12-27-44-05602		\$4,437.50
1	Permit and inspection of sidewalk installation		\$244.07
	THANK YOU for your support of this project!		
		SUBTOTAL	
		SHIPPING & HANDLING	
		TOTAL DUE	\$4,681.57

Make all checks payable to City of Florence
 If you have any questions concerning this invoice, contact Mike Miller 541-997-4106

Thank you for your business!

**CITY OF FLORENCE PUBLIC WORKS
 RIGHT OF WAY EXCAVATION WORK PERMIT**

Applicant (City Approved Contractor) Marion Castleman

Applicant's Address [REDACTED] Florence, OR 97439 Phone _____

Purpose of Excavation: Sewer Water Driveway Curb Cut Sidewalk Other _____

Attention: Oregon law requires you to follow rules adopted by the Oregon Utility Notification Center. Those rules are set forth in OAR 952-001-0010 through OAR 952-001-0090. You may obtain copies of the rules by calling the center. (Note: the Telephone number for the Oregon Utility Notification Center is (503) 232-1987. For locates, call 1-800-332-2344.)

One-Call Center Identification No. (for this project): _____ Planning #: _____

Description of Work: Installation of sidewalk along 7th Street between alley and 1/2 of street frontage

Project Address	Start Date	Completion Date	Surface Type	Total ROW Work
Tax lot 18-12-27-44-05602			Conc	60

* Asphalt to be patched to grade the same day per Inspector's Instructions.

**Street Cuts on Arterials & Collectors will be hot patched the day of the cut.

I agree to comply with all provisions of City of Florence FCC Title 8 Chapter 2 Standards & Specifications for excavating and restoring any Public Improvement, holding the City of Florence harmless from any liability of any kind resulting from or in connection with my/our activities in excavating and restoring any Public Improvement.

X Signed: _____ Date: 5/23/2024

Insurance Certificate on file, \$1,000,000.00 blanket coverage endorsed for completed operations through the fast permanent restoration of City Streets.

Plans Attached W & S Fees Paid **Copies To:** Permittee Public Works Address File

OFFICE USE ONLY		INSPECTOR APPROVAL
Basic Permit Fee	\$45.87	Comments:
Lineal foot charge (\$1.72/LF) ALL Right of Way Work	\$ 103.20	Evergreen Concrete \$4,437.50
Inspection Fee \$84 Water/Sewer Line	\$	Ray Wells \$4,000
Inspection Fee \$95/hr Street/Curb/Sidewalk 1 Hour Minimum	\$ 95	Driveway approach at Alley & 7th \$3,562.50
TOTAL DUE:	\$ 244.07	

Inspection Date _____ Inspector _____

Remarks _____

Sidewalk along Laurel Street is \$4,437.50. Quote from Evergreen Concrete. This is to be paid by property owner.

City to pay and complete the alley driveway approach at 7th Street.

Approval: Michael Miller Date: 5/23/2024

CITY OF FLORENCE
CONSTRUCTION PERMIT IN PUBLIC RIGHT OF WAY
Per ordinance no. 14, series 2007

Applicant: Marion Castleman Engineer/Contractor: Evergreen Concrete
Address: _____ Address: _____
Phone: _____ Phone: _____
Signature of person with authority to bind applicant: _____
Applicant's registered agent in the State of Oregon: _____

CONSTRUCTION SITE

Assessor's Map: _____
Location: _____ Tax Lot No. 18-12-27-44-05602

TYPE OF CONSTRUCTION

Opening Paved Street – DEPOSIT REQUIRED
 Opening Unpaved Street – DEPOSIT REQUIRED
 Curb Cuts Number of Cuts Frontage of Lot 60 feet
 Private Construction within right of way
 Sewer Connection/Tap
 Driveway
 Sidewalk Construction
 Other (Describe the nature of work and intended purpose) _____

8 foot wide sidewalk along 7th Street - 8'W x 60' long

PERMIT REQUIREMENTS

Application approved by appropriate department – (attach construction plans)
 Deposit \$ _____
 Fee \$ 244.07
Total Paid \$ _____

Contractor Shall Provide

Contractor's License Number and Expiration Date: 206667
Contractor's Insurance Company and Policy Number: 100053840
Amount of Insurance carried by Contractor: \$1,000,0000
Amount of Insurance required by City: _____
Amount of Bonding required by the City – if applicable: _____
Emergency Contact Information: 541-999-1506

*Contractor must furnish proof of the above before this permit is issued.

Contractor Will Give

1. Notification to Public Work Department of start date of the project.
2. Notification of project inspection during construction.
3. Notification of project completion date.
4. Notification for final inspection and approval.
5. Notification of approval of the project by the City applicant. This information will be sent by the City Recorder, and any deposits will be returned upon satisfactory completion of the project.
6. A set of as-built plans will be given to the City, if applicable.
7. Engineered drawings showing detailed plans for all facilities.
8. Map(s) showing location of all facilities.



THIS PERMIT IS NOT TRANSFERABLE

INSURANCE WAIVER:

I, Evergreen Concrete, LLC, agree to save the City, its officials, employees, and agents harmless from any and all costs, damages and liabilities which may accrue or be claimed from any and all costs, damages and liabilities which may accrue or be claimed to accrue by reason of any work performed under this permit. I am also aware of all requirements of Ordinance No. 14, Series 2007.

PENALTIES: On conviction of failure to comply with Ordinance No. 14, Series 2007, a fine not to exceed \$200 for each day violation continues to persist after due notice has been given.

APPROVED BY:

Michael Miller
Public Works Director

5/23/2024
Date:

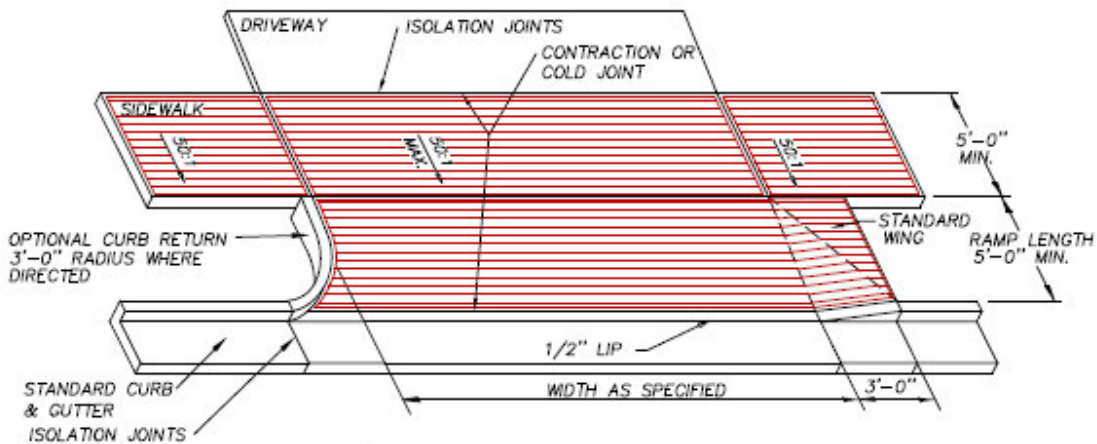

DRIVEWAY / ALLEY APPROACH FOR SET-BACK SIDEWALK

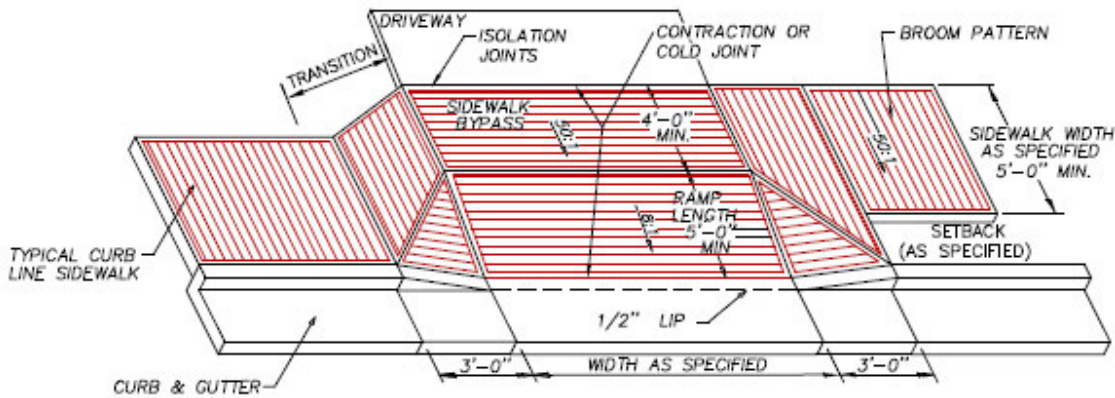

DRIVEWAY / ALLEY APPROACH FOR CURBSIDE & PARTIALLY SET-BACK SIDEWALKS

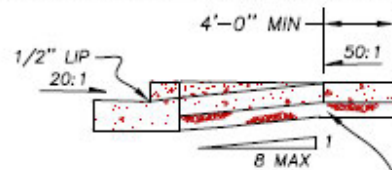

TYPICAL SECTION THROUGH RAMP

NOTES:

- 1) RESIDENTIAL DRIVEWAYS AND SIDEWALK SECTIONS THROUGH DRIVEWAYS SHALL HAVE A MINIMUM NORMAL THICKNESS OF 6". CONCRETE STRENGTH SHALL BE 3300 PSI.
- 2) CONCRETE FOR COMMERCIAL USE AND ALLEY APPROACHES SHALL HAVE A MINIMUM NOMINAL THICKNESS OF 8". CONCRETE STRENGTH SHALL BE 3300 PSI.
- 3) CURB TRANSITIONS FOR COMMERCIAL USE AND ALLEY APPROACHES SHALL BE 5 FT.
- 4) CONSTRUCT CONTRACTION JOINT IN CENTER OF DRIVEWAY WHEN DRIVEWAY WIDTH EXCEEDS 15'.
- 5) NO LIP AT GUTTER IF USED AS SIDEWALK ACCESS RAMP.
- 6) SEE SIDEWALK DETAILS FOR RESTRICTIONS AND SPECIFICATIONS NOT SHOWN.
- 7) THE 50:1 CROSS-SLOPE OF SIDEWALK IS MEASURED FROM HORIZONTAL. THE 12:1 SLOPE OF SIDEWALK TRANSITION TO DRIVEWAY/ALLEY IS RELATIVE TO THE RUNNING SLOPE OF THE SIDEWALK. THE SLOPE OF THE APRON IS MEASURED RELATIVE TO HORIZONTAL.

**CITY OF FLORENCE
STANDARD DRAWING**

**DRIVEWAY AND ALLEY
APPROACHES FOR
SETBACK OR
BYPASS SIDEWALK**

DATE:
MARCH 2007

DRAWING NO.
F-208A

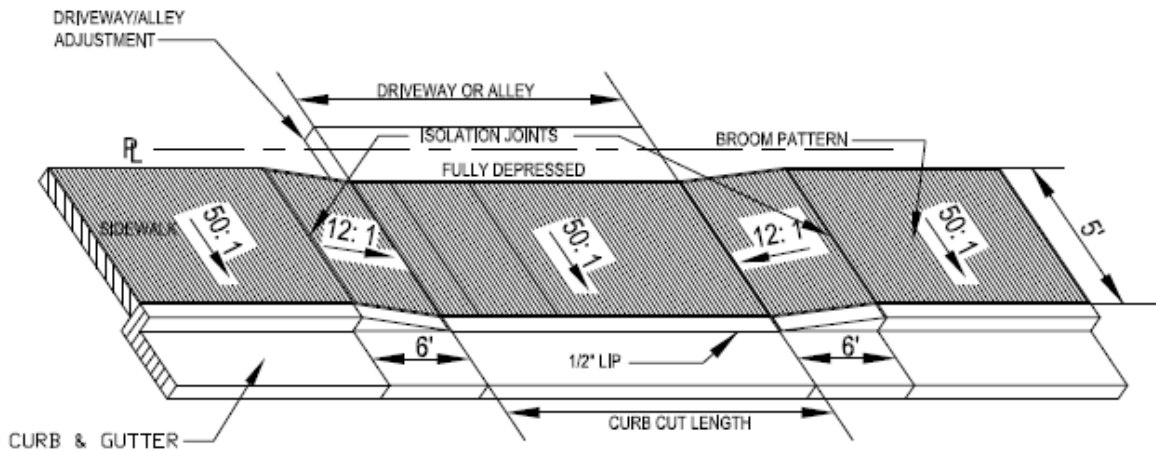

CURBSIDE - SIDEWALK APRON FOR 5' WALKS

SLOPE:

50: 1 (2%)

12: 1 (8%)

NOTES:

1. ALL CONCRETE SHALL BE 6" INCH MINIMUM THICKNESS OF 3,000 psi. FIELD STRENGTH
2. ADD JOINT IN CENTER OF APRON AND CURB & GUTTER WHEN APRON WIDTH EXCEEDS 20' FT.
3. ALL SLOPES ARE RELATIVE TO HORIZONTAL.
4. IF THE APRON WILL ALSO SERVE AS A SIDEWALK ACCESS RAMP IN PLACE OF A STANDARD RAMP, THE APRON SLOPE FROM THE GUTTER TO THE SHALL BE 12: 1 OR LESS WITH NO LIP.

**CITY OF FLORENCE
STANDARD DRAWING**

**DRIVEWAY AND
ALLEY APRON
5' CURBSIDE
SIDEWALK**

DATE:
9-22-11

DRAWING NO.
F-208B

**CITY OF FLORENCE
PLANNING COMMISSION**

RESOLUTION PC 23 19 CUP 02

A REQUEST FOR A CONDITIONAL USE PERMIT TO CONSTRUCT A SINGLE-UNIT DETACHED DWELLING AT 7TH STREET AND LAUREL STREET IN MAINSTREET AREA B, TEMPORARY CONDITIONAL USE PERMIT FOR A CONSTRUCTION SITE DWELLING, AND A VARIANCE REQUEST TO DECREASE REAR AND FRONT YARD SETBACKS.

WHEREAS, application for a conditional use permit was made by Marion Castleman for a conditional use permit as required by FCC 10-1-1-4, FCC 10-1-1-6-3, and FCC 10-4-10; and

WHEREAS, application for a temporary construction site dwelling was made by Marion Castleman for a temporary conditional use permit as required by FCC 10-1-1-4, FCC 10-1-1-6-3, and FCC 10-4-12-E; and

WHEREAS, application for a variance was made by Marion Castleman for decreased front and rear yard setbacks as required by FCC 10-1-1-4, FCC 10-1-1-6-3, and FCC 10-5-3; and

WHEREAS, the Planning Commission/Design Review Board met in a public hearing on November 14, 2023, as outlined in Florence City Code 10-1-1-6-3, to consider the application, evidence in the record, and testimony received; and

WHEREAS, the Planning Commission/Design Review Board determined per FCC 10-4-6, after review of the application, testimony, and evidence in the record, that the application meets the criteria through compliance with certain Conditions of Approval; and

WHEREAS, the Planning Commission/Design Review Board of the City of Florence finds, based on the Findings of Fact, staff recommendation, and evidence and testimony presented to them, that the application meets the applicable criteria.

NOW THEREFORE BE IT RESOLVED that the Planning Commission/Design Review Board of the City of Florence finds, based on the Findings of Fact and the evidence in record, that:

The request for a Conditional Use Permit for a single-unit detached dwelling, temporary conditional use permit for construction site dwelling, and variance request for decreased rear and front yard setback by 5 feet each meets the applicable criteria in Florence City Code with the conditions of approval as listed below.

Conditions of Approval:

The application, as presented, meets or can meet applicable City codes and requirements, provided that the following conditions of approval are met.

1. Approval for shall be shown on:
 - “A” Findings of Fact
 - “B” Land Use Application
 - “C” Site Plans
 - “D” Referral Comments
 - “E” Public Testimony

2. Findings of Fact attached as Exhibit "A" are incorporated by reference and adopted in support of this decision. Any modifications to the approved plans or changes of use, except those changes relating to Building Codes, will require approval by the Community Development Director or Planning Commission/Design Review Board.

3. Regardless of the content of material presented for this Planning Commission, including application text and exhibits, staff reports, testimony and/or discussions, the applicant agrees to comply with all regulations and requirements of the Florence City Code which are current on this date, EXCEPT where variance or deviation from such regulations and requirements has been specifically approved by formal Planning Commission action as documented by the records of this decision and/or the associated Conditions of Approval. The applicant shall submit to the Community Development Department a signed "Agreement of Acceptance" of all conditions of approval prior to issuance of a building permit.

4. Upon encountering any cultural or historic resources during construction, the applicant shall immediately contact the State Historic Preservation Office and the Confederated Tribes of Coos, Lower Umpqua, and Siuslaw Indians. Construction shall cease immediately and shall not continue until permitted by either a SHPO or CTCLUSI representative.

5. **Off-Street Parking and Loading**

5.1 The driveway on site shall be constructed of durable and dust free surfacing in accordance with FCC 10-3-8 at a minimum of 50 feet from the 7th Street ROW, but shall not be less than the required 20 feet of driveway setback to the carport.

5.2 Either the west portion of the carport shall be enclosed or fencing or landscaping a minimum of 3 feet in height shall be installed and maintained along the west portion of the property in accordance with FCC 10-34 to screen headlights from encroaching on residential properties to the west.

5.3 In accordance with FCC 10-3-2-E, at no time shall on-site parking for this site impede the flow of traffic or encroach into the alley abutting this property.

6. **Conditional Use Permits & Variances**

6.1 Authorization of a conditional use permit shall be void one (1) year after the date of approval, November 14, 2024 unless substantial construction has taken place in accordance with requirements of FCC 10-4-8-A (see **Condition 6.9** below for required time line for construction and installation of the dwelling unit).

6.2 A paved pedestrian walkway shall be installed from the required sidewalks along the 7th Street frontage to the front entrance of the dwelling that is designed in accordance with FCC 10-35-2-9.

6.3 A temporary construction site dwelling may be placed on Assessors Map 18-12-27-44 Tax Lot 5602 or 5601. The temporary construction site dwelling shall not obstruct or encroach onto public ROW and the temporary dwelling shall not be sited within required setbacks.

6.4 The temporary construction site dwelling shall be removed before installation of the

- carport structure to avoid construction from preventing the removal of the temporary dwelling in accordance with FCC 10-4-12-E-3.
- 6.5** The variance request is determined to be the most practical solution to the rear and front yard setback problems (FCC 10-5-2-B-1). The setback shall be reduced to 5 feet for the rear yard setback for the covered parking structure. The manufactured home has dimension constraints that a site-built home may not. Therefore, the front yard setback shall be decreased to 5 feet only if the site is developed with a manufactured home.
 - 6.6** The carport shall have a minimum 10-foot setback from the west property line in accordance with the code intent of FCC 10-10-4-D which requires a minimum 10-foot setback from the rear property line.
 - 6.7** At all times during construction and while the temporary construction site dwelling is located on the subject site the property shall be maintained in a manner that is compliant with FCC 6-1-8 which regulates nuisances within City Limits.
 - 6.8** In accordance with FCC 10-4-12-E-3-g, the temporary CUP for the construction site dwelling expires 3 calendar days following final inspection approval for the primary dwelling.
 - 6.9** The construction and installation of the manufactured home and approved final inspections shall be completed within 180 days from the end of the appeal period. If construction is not completed within 180 days from the end of the appeal period then application for an extension shall be submitted in writing in accordance with FCC 10-4-8-A.
 - 6.10** Within 3 days of an approved final inspection Lot 5601 shall be cleared of all items, materials, and structures until such a time that this lot has an approved use through the City land use approval process).

7. Residential Districts

- 7.1** The manufactured homes shall meet all design criteria and development for manufactured homes in accordance with FCC 10-10-10. These criteria will be reviewed for compliance during building plan review.

8. Mainstreet Area B

- 8.1** The site shall meet lighting standards in accordance with FCC 10-27-4-G including using lighting fixtures that conform to the Architectural Guidelines and lighting that is pedestrian scale. This is in addition to lighting requirement in accordance with FCC 10-37. Lighting fixtures and plan shall be submitted and reviewed in at time of building plan review.
- 8.2** A trash enclosure shall be located in the rear or side yard and screen from street or pedestrian view with a permanent solid wood fence or wall at least 6 feet in height in accordance with FCC 10-27-4-I. This trash enclosure location and materials shall be submitted and reviewed during building plan review and shall be installed prior to Certificate of Occupancy.

9. Access and Circulation

- 9.1** The allowance of the variance for the decreased front yard setback to allow for the covered front porch does not supersede FCC 10-35-2-14 code criteria for minimum vision clearance. All minimum vision clearance shall be maintained.
- 9.2** In accordance with FCC 10-35-3-1-A and FCC 10-36-2-16 a sidewalk built to City standards with approval from the Public Works Directors shall be constructed along the street frontage of the property seen on assessors Map 18-12-27-44 Tax Lot 5602 prior to issuance of occupancy. A work in ROW permit shall be obtained from the City Public Works Department prior to any work in the ROW.

10. Public Facilities

- 10.1** The curb cut at the intersection of 7th street and the alley contiguous with the east property line shall be built to applicable City and ADA standards with approval from the City of Florence Public Works Director prior to issuance of Certificate of Occupancy.
- 10.2** The applicant shall have approval from the USPS for the location of a mailbox onsite prior to installation or placement in accordance with FCC 10-36-2-22.
- 10.3** All utilities shall be placed underground in accordance with FCC 10-36-5-C

Informationals:

1. FCC 6-1-8 regulations related to nuisances and FCC 10-27-5-J related to general provisions in the Mainstreet Areas will apply to this project consistent with other properties in the zone with similar approved uses.
2. Following construction, the RV may only be stored on site in a means permitted in code and shall not be used as a dwelling past the permitted timer period in Condition of Approval 6.4
3. In accordance with FCC 10-5-6-B the variance request shall be valid for 1 year following Planning Commission approval (November 14, 2024) unless substantial construction has taken place or a written request for extension has been submitted to the City Planning Department.
4. Compliance with building height and minimum roof slope in accordance with FCC 10-10-5-A shall be reviewed at the time of building plan review as is standard practice with detached single unit dwelling in medium density residential zoning districts.
5. Prior to any work in the public ROW a work in the ROW permit shall be obtained from the City of Florence Public Works Department.
6. Maximum building in Mainstreet Area B is 90% lot coverage by all buildings and other impervious surfaces. This will be reviewed during building plan review.
 - $2520 \times .90 = 2,268$ sq. ft is the maximum lot coverage permitted
7. In accordance with FCC 10-4-8-B the discontinuance of use for 12 consecutive months

constitutes an expiration of the conditional use.

8. All lighting on site, other than those which are exempt under FCC 10-37-5-R, shall be in compliance with FCC 10-37. This is in addition to requirement of Condition **8.2** of this resolution.

ADOPTED BY THE FLORENCE PLANNING COMMISSION/DESIGN REVIEW BOARD
the 14th day of November 2023.



Sandra Young, Chairperson
Florence Planning Commission

November 15, 2023

DATE

**FINDINGS OF FACT
FLORENCE PLANNING COMMISSION
Exhibit "A"**

Public Hearing Date: November 14, 2023
Application: PC 23 19 CUP 02

Planner: Clare Kurth

Exhibit G

I. PROPOSAL DESCRIPTION

Proposal: A request for conditional use permits to construct a single-unit detached dwelling in Mainstreet Area B and a temporary construction site dwelling. Variance requests for a decreased front yard setback to allow for a covered front porch and a decreased rear yard setback.

Applicant: Marion 'Bud' Castleman

Property Owners: Marion 'Bud' Castleman

Location: 7th Street and Laurel Street

Site: Map # 18-12-27-44 Tax lot 05602 and 05601

Comprehensive Plan Map Designation: Main Street Area B (MSB)

Zone Map Classification: Downtown

Surrounding Land Use / Zoning:

Site: Undeveloped / Main Street Area B (MSB)
North: Single-Unit Dwelling & Utility Facility / High Density Residential (HDR)
South: Single-Unit Dwelling / MSB
East: Office Building & Single-Unit Detached Dwelling / MSB
West: Single-Unit Detached Dwelling / HDR

Streets / Classification:

East – none / alley; North – 7th Street / Local; West – Laurel Street / Local; South – none

II. NARRATIVE:

The applicant proposes to develop a detached single-unit dwelling (SUD) at a lot located east of the SE corner of the intersection of 7th and Laurel Streets in the Mainstreet Area B zoning district. The proposed development includes associated development structures including driveway access off the existing improved alley and a carport. During construction on site, the applicant has requested a temporary construction site dwelling in the form of an RV to reside on the lot during construction.

There are two lots on this site both with the same property owner; Lot 5602 is on the east half of the site and abuts the alley with street frontage on 7th; Lot 5601 is on the western half of the site and has street frontage along 7th street and Laurel Street.

APPROVED
City of Florence
Planning Commission
Clare Kurth

The western lot is proposed to be used as the site for the temporary construction dwelling. Due to the small size of these lots, there is not adequate space for both construction on site and the temporary construction site dwelling on Lot 5602. For the purposes of this review process the two lots will be considered a single development site.

In addition to the two conditional use permits, a variance request has been made to reduce the rear yard setback and the front yard setback by 5 feet each, which represents a 50% reduction. The variance for the decreased front yard setback is to allow for a roof over the front porch. In accordance with FCC 10-2 a front porch not greater than 3 ½ feet high without a roof covering is permitted in the front yard setback. The rear yard variance is requested to permit the carport to be 5 feet from the rear lot line rather than the 10 feet required for parking structures under FCC 10-10-4. Both of these requests can be compliant with either Florence City Code or the Comprehensive Plan.

This application consists of four separate requests to be consolidated and processed simultaneously for Planning Commission review and decision.

1. Conditional Use Permit for a detached SUD in MSB.
2. Temporary Conditional Use Permit for construction site dwelling.
3. Variance for a decreased front yard setback to 5 feet for a covered front deck.
4. Variance for a decreased rear yard setback from 10 feet for the carport to 5 feet.

The detached SUD proposed is anticipated to be a manufactured home. At the time of the writing of these Findings the applicant has not selected a specific model which is deemed acceptable as detached SUDs are exempt from design review.

The significance of the dwelling being a manufactured dwelling is that this type of housing unit has dimension constraints that a site-built home does not have. According to the [Homes Direct website](#) (the manufactured home company the applicant plans use), the average dimensions of a manufacture home are 14 to 18 feet wide and 66 to 80 feet in length. The maximum dimension of a unit the lot can fit, with proposed decreased setbacks, and required covered parking, is 15 feet x 50 feet. The maximum dimension of the manufactured home that can fit on this site limits the options available. The setback for a garage or carport on a side yard is 5 feet, but is 10 feet in the rear yard with the intent of head in parking and providing screening and buffering from the adjacent property, which would be the west property in this case.

The property is 42 feet deep and cannot accommodate access from 7th Street along with the required 10' set back, carport (20 feet), and 20-foot setback from the front property line. The Driveway in the rear of the house is preferable to minimize visual impact of vehicle storage, but also for meeting minimum driveway to street pavement requirements. The proposed location of the carport is the most feasible location and can meet the intent of the code, but not strict adherence to it.

Manufactured homes require a crawlspace and therefore will be required to have a front porch. Uncovered porches under 3 ½ feet high are permitted structures in a front yard setback. Without the variance the dwelling is permitted under current code to have a front porch, but not be over 3 ½ feet in height and not covered. The variance request will permit a coved deck and railings for safety to be install. The rational for how this can meet the Comprehensive Plan goals is discussed in more detail under FCC 10-5.

This application request is for the 4 items listed above. This application is not a request for the design review of the residential unit as detached SUD are exempt from design review. Design review criteria related to single-unit residential development standards will be review during building permit review for compliance with development standards under FCC 10-10-5 and FCC 10-10-10, as is typical with detached single-unit dwellings in zoning district where this type of housing is permitted outright.

These Findings are included in chronological order as found in Florence City Code, Title 10. These Findings will be organized as follows:

- Chapter 1 discusses application and public hearing process and procedures.
- Chapter 3 discusses off street parking as it pertains to single-unit detached dwellings, which includes a discussion on the required covered parking and driveway surfacing materials.
- Chapter 4 discusses conditional use permits and temporary conditional use permits. This section will discuss both the request for the conditional use permit for the single-unit dwelling in Mainstreet Area B and will also discuss the request for the temporary conditional use permit for the construction site dwelling.
- Chapter 5 regulates variances and will review the requests against code criteria.
- Chapter 10 regulates residential districts and under FCC 10-27-5 a detached SUD in Mainstreet Area B is regulated as Medium Density Residential. So, Chapter 10 was included for review of development and site provision as the relate to Medium Density Residential and FCC 10-10-10 that regulates manufactured homes not in a manufactured home park.
- Chapter 27 regulates Mainstreet Areas and was included as this is the zoning district the subject site is located in.
- Chapters 34 through 37 were included as they relate to development provisions for detached SUD including items such as site access requirements, utilities, and residential lighting exemptions.

III. NOTICES & REFERRALS:

Notice: On October 25, 2023, notice was mailed to surrounding property owners within 300 feet of the property. The property was posted on October 25, 2023. Notice was published in the Siuslaw News on November 10, 2023.

The City has received the following public testimony:

Nov. 6, 2023 – Lepore: Testimony included images of the site. This testimony included 3 main concerns with request for Planning Commission Consideration.

1. Requesting a firm date for removal of existing construction materials on site.
2. Time limit for duration the temporary RV dwelling may be on site.
3. If Lot 5601 is permitted to continue to be used as storage a solid fence to be installed.

Response: The storage of construction materials on a vacant lot is not an approved use for a vacant lot in Mainstreet Area B. Once the site is developed the storage of items can continue if in compliance with FCC 10-27-5-J which states 'Outdoor storage of materials. . . shall be subject to approval by the Design Review Board'. The Planning Commission serves as the City's design review board.

The time line for the duration the temporary construction site dwelling (RV) is that it must be removed before Certificate of Occupancy for the primary dwelling can be issued and within 3 days of the approval of final inspection in accordance with FCC 10-4-12-E-3-g. At the Planning Commission's discretion, a firm date or specified timeline may be established. The RV may continue to be stored on private residential property, but not used as a dwelling.

The CUP for the SUD is for Lot 5602. While lot 5601 is considered part of this site for the purposes of review, it does not currently have an approved use. Permitted uses in the Mainstreet Areas are listed in FCC 10-27-2. A separate land use application and review will be required for development of Lot 5601.

Referrals: Referrals were sent on October 26, 2023 the City of Florence Public Works Department, Police Department, Code Enforcement, and Building Department. The same referral was sent to the Siuslaw Valley Fire and Rescue, CLTCLUSI, ODOT, CLPUD, and local internet and telecommunications providers.

At the time of this report, the City has received referral comments from the following agencies:

Public Works: States that the *"the property is to take access from the alley for the eastern lot. The alley approach does not meet current design criteria for ADA accommodations, therefore the City will replace the alleyway approach. In conjunction with the alleyway approach reconstruction, the applicant/developer shall install a 6 foot (5'-6" wide sidewalk adjacent to the back of the existing curb) along the lot frontage of 7th Street. The second half of the sidewalk (for the west lot) shall be constructed at time the west lot is developed.*

Currently both water and wastewater services have been installed and available to the lots."

Lumen: States there is an aerial cable located on the north edge of the property running east to west along 7th Street. No issues are anticipated,

Agency referrals are used to determine the need for conditions of approval within their applicable review criteria.

IV. APPLICABLE REVIEW CRITERIA

Florence City Code, Title 10:

- Chapter 1: Zoning Administration, Sections 1-4, 1-5; 1-6-3; 1-7
- Chapter 3: Off-Street Parking and Loading, Sections 3-A, 4-A, 8-A, 8-D, 8-F, and 8-J
- Chapter 4: Conditional Uses, Sections 3 through 11 and 12-E-3
- Chapter 5: Zoning Adjustments & Variance, Sections 2 through 7
- Chapter 10: Sections 2, 4 through 5, and 10

- Chapter 27: Mainstreet District, Sections 3 through 5
- Chapter 34: Landscaping, Section 5
- Chapter 35: Access & Circulation, Sections 2-2, 2-3, 2-6 through 2-8, 2-12 through 2-14, & 3-1
- Chapter 36: Public Facilities, Sections 2-7, 2-16 through 2-18, 2-22, 3, and 5
- Chapter 37: Lighting, Section 5R

Realization 2020 Florence Comprehensive Plan:

- Chapter 2: Land Use, Residential Policy 9
Land Use, Downtown Planning Area Policy 1
- Chapter 12: Transportation Policy 10

V. FINDINGS: CONDITIONAL USE PERMIT

FLORENCE CITY CODE

TITLE 10: CHAPTER 1: ZONING ADMINISTRATION

10-1-1-6-3: TYPE III REVIEWS – QUASI-JUDICIAL LAND USE HEARINGS:

- A. Hearings are required for Type III (quasi-judicial) land use matters requiring Planning Commission review. Type III applications include, but are not limited to:**
 - 6. Conditional Use Permits.**
 - 7. Variances**

The applicant proposes a detached SUD in the Mainstreet Area B (MSB) zoning district, which requires a conditional use Type III process that includes a quasi-judicial public hearing. The variance requests require a Type III quasi-judicial land use hearing. This criterion is met through this review process.

B. Notification of Hearing:

- 1. At least twenty (20) days prior to a Type III (quasi-judicial) hearing, notice of hearing shall be posted on the subject property and shall be provided to the applicant and to all owners of record of property within 100 feet of the subject property, except in the case of hearings for Conditional Use Permits, Variance, Planned Unit Development and Zone Change, which notice shall be sent to all owners of record of property within 300 feet of the subject property.**
 - d. Notice shall be mailed to any person who submits a written request to receive notice.**
- 2. Prior to a Type III (quasi-judicial) hearing, notice shall be published one (1) time in a newspaper of general circulation. The newspaper’s affidavit of publication of the notice shall be made part of the administrative record.**

Notice of the public hearing was posted on the subject property and mailed to all property owners within 300 feet of the property on October 25, 2023. Notice was published within the Siuslaw News one time on November 10, 2023. These criteria are met.

C. Notice Mailed to Surrounding Property Owners - Information provided:

- 1. The notice shall:**
 - a. Explain the nature of the application and the proposed use or uses which could be authorized;**
 - b. List the applicable criteria from the ordinance and the plan that apply to the application at issue;**
 - c. Set forth the street address or other easily understood geographical reference to the subject property;**
 - d. State the date, time and location of the hearing;**
 - e. State that failure of an issue to be raised in a hearing, in person or by letter, or failure to provide sufficient specificity to afford the decision maker an opportunity to respond to the issue precludes further appeal based on that issue;**
 - f. State that application and applicable criteria are available for inspection at no cost and will be provided at reasonable cost;**
 - g. State that a copy of the staff report will be available for inspection at no cost at least 7 days prior to the hearing and will be provided at reasonable cost;**
 - h. Include a general explanation of the requirements for submission of testimony and the procedure for conduct of hearings.**
 - i. Include the name of a local government representative to contact and the telephone number where additional information may be obtained.**

The provided notice contained all information listed in FCC 10-1-1-6-3-C. These criteria are met.

D. Hearing Procedure: All Type III hearings shall conform to the procedures of Florence City Code Title 2, Chapters 3 and 10.

E. Action by the Planning Commission:

- 1. At the public hearing, the Planning Commission shall receive all evidence deemed relevant to the issue. It shall then set forth in the record what it found to be the facts supported by reliable, probative and substantive evidence.**
- 2. Conclusions drawn from the facts shall state whether the ordinance requirements were met, whether the Comprehensive Plan was complied with and whether the requirements of the State law were met.**
- 3. In the case of a rezoning request, it shall additionally be shown that a public need exists; and that the need will be best served by changing the zoning of the parcel of land in question.**

4. **There is no duty upon the Planning Commission to elicit or require evidence. The burden to provide evidence to support the application is upon the applicant. If the Planning Commission determines there is not sufficient evidence supporting the major requirements, then the burden has not been met and approval shall be denied.**

The Planning Commission held a public hearing on November 14, 2023 which met the standards of FCC 2-3 and FCC 2-10. These criteria are met.

TITLE 10: CHAPTER 3: OFF-STREET PARKING AND LOADING

10-3-2: GENERAL PROVISIONS:

- A. **The provision for and maintenance of off-street parking and loading spaces are continuing obligations of the property owners. No building or other permit shall be issued until plans are presented that show property that is and will remain available for exclusive use as off-street parking and loading space.**
- B. **At the time of new construction or enlargement or change in use of an existing structure within any district in the City, off-street parking spaces shall be provided as outlined in this Chapter, unless requirements are otherwise established by special review or City Council action. Additional parking spaces shall meet current code.**
- C. **If parking space has been provided in connection with an existing use or is added to an existing use, the parking space shall not be eliminated if elimination would result in less space than is required by this Chapter.**
- D. **Required parking spaces shall be available for the parking of passenger automobiles of residents, customers, patrons and employees, and shall not be used for storage of materials of any type.**

Parking will be discussed further under FCC 10-3-3 and FCC 10-3-8.

- E. **Ingress and egress for parking and loading shall not endanger or impede the flow of traffic.**

Access will be reviewed under section FCC 10-35 below.

10-3-3: MINIMUM STANDARDS BY USE: The number of required off-street vehicle parking spaces shall be determined in accordance with the standards in Table 10-3-1. Where a use is not specifically listed in this table, parking requirements are determined by finding that a use is similar to one of those listed in terms of parking needs, or by estimating parking needs individually using the demand analysis option described below:

- A. **Parking that counts toward the minimum requirement is parking in garages, carports, parking lots, bays along driveways, and shared parking. Parking in driveways does not count toward required minimum parking. For single family**

dwelling, duets and duplexes, one parking space per unit may be provided on a driveway if the criteria in FCC 10-3-8 are met.

Two parking spaces are proposed. One is proposed as covered parking under a 12' x 20' carport and the other is proposed in the driveway that takes access from the existing alley. Additional details relating to parking area improvements will be discussed under FCC 10-3-8.

10-3-4: MINIMUM REQUIRED PARKING BY USE: During the largest shift at peak season, fractional space requirements shall be counted as the next lower whole space (rounded down). Square footages will be taken from the gross floor area (measurements taken from exterior of building). Applicants may ask the Design Review Board a reduction for parking spaces as part of their land use application. The applicant will have to provide the burden of evidence to justify the reduction proposed. The Design Review Board and/or staff may require the information be prepared by a registered traffic engineer. Table 10-3-1 lists the minimum parking spaces required by use, with a minimum no less than two (2) spaces.

Table 10-3-1, Minimum Required Parking by Use:

A. Residential and Commercial Dwelling Types:

Single Family Dwelling including attached and detached dwellings and manufactured homes	2 spaces per dwelling unit on a single lot
--	---

The applicant is proposing a detached SUD, which includes a carport and a parking space in the driveway. 2 parking spaces are required and 2 parking spaces are proposed. This criterion is met.

10-3-8: PARKING AREA IMPROVEMENT STANDARDS: All public or private parking areas, loading areas and outdoor vehicle sales areas shall be improved according to the following: All required parking areas shall have a durable, dust free surfacing of asphaltic concrete, cement concrete, porous concrete, porous asphalt, permeable pavers such as turf, concrete, brick pavers or other materials approved by the City. Driveways aprons shall be paved for the first fifty feet (50') from the street.

The proposed parking area and driveway shall be improved with a durable dust free surface in accordance with this code section within the first 50' from the 7th Street ROW and, at a minimum, the uncovered portion of the proposed driveway onsite, which shall be a minimum of 20 feet in length starting the alley pavement. (Condition 5.1) This criterion is conditioned to be met.

A. Parking for new single-family dwellings and duplexes shall be provided as follows:

- 1. A carport or garage, unless the majority of existing dwellings within 100 feet of the property boundary of the proposed development do not have such covered parking facilities. The number of required covered parking spaces shall be based on the predominant number of covered spaces on the majority of lots within the 100-foot radius. Parking spaces shall measure nine (9) feet and six (6) inches wide by nineteen (19) feet long. No encroachments (such as water heaters, steps, door swings) are allowed into the required parking spaces.**
- 2. One parking space per unit may be provided on a driveway if the following criteria are met: a. Driveway spaces shall measure at least nine (9) feet and six (6) inches**

wide by nineteen (19) feet long. No encroachments are allowed into the required parking spaces. b. Driveway spaces shall not extend into the public right-of-way. c. The number of parking spaces provided as a carport or garage shall not fall below one (1) space per unit.

The majority of the single-unit dwellings within 100 feet from the project site have covered parking and vary between 2 car garages and 1 car garages. This project proposes 1 covered parking space. The proposed 12'x 20' carport is determined to meet this code section and is in keeping with the predominate number of parking spaces in the surrounding 100 feet of the property.

The subject site does not have adequate square footage or necessary site dimensions to accommodate additional covered parking. Requiring additional covered parking spaces is not required based on this code section and is not feasible for the site. This criterion is met.

D. Parking spaces shall be located or screened so that headlights do not shine onto adjacent residential uses.

The required covered parking is a proposed carport, which is required by Oregon Building Codes to remain open on a minimum of 2 sides. The western portion of this lot is undeveloped and there is a potential for headlights to shine onto the residential property located on the west side of Laurel St. The applicant shall either enclose the west end of the carport or include fencing or landscaping, in accordance with FCC 10-34, a minimum of 3' high to screen headlights from residential properties to the west. (Condition 5.2) This criterion is conditioned to be met.

F. No parking area shall extend into the public way except by agreement with the City.

No parking area has been proposed which extends into the public ROW. At no time shall parking for this site encroach into the alley or impede traffic in the alley that abuts this property to the east (Condition 5.3). This criterion is met.

H. Lighting: Refer to Section 10-37 of this Title for requirements.

Lighting shall be discussed under section FCC 10-37.

J. Unless otherwise provided, required parking and loading spaces shall not be located in a required front or side yard.

Required parking is proposed on the rear of the lot behind the proposed dwelling unit. The driveway parking is proposed partially in the side yard. Parking in the driveway is permitted for single-unit dwellings in accordance with FCC 10-3-8-A-2. This Code section is likely intended to address parking in a parking lot rather than in a residential housing type that permits parking in the driveway.

The covered carport parking is situated entirely in the rear yard. This criterion is met.

TITLE 10: CHAPTER 4: CONDITIONAL USES

10-4-3: USE PERMIT PREREQUISITE TO CONSTRUCTION: When a conditional use permit is required by the terms of this Title, no building permit shall be issued until the conditional use permit has been granted by the Planning Commission, and then only in accordance

with the terms and conditions of the conditional use permit. Conditional use permits may be temporary or permanent.

10-4-4: APPLICATIONS: The application for a conditional use permit shall be made in writing to the Planning Commission by the owner of the land in consideration or his agent, duly authorized in writing. The application shall include the following information:

A. Site and building plans and elevations.

A site plan with proposed building locations, dimensions, and setbacks was provided. Detached SUDs are not subject to design review. Exterior building elevations were not submitted and are not required as part of this application. These criteria are met.

B. Existing conditions on the site and within three hundred feet (300') of a site that is one (1) acre or larger and within one hundred feet (100') from a site that is less than one (1) acres in size.

Existing conditions on the site were included on the application. The subject lot is vacant and mostly cleared of vegetation. Existing conditions on adjacent sites was discussed earlier in these Findings. This criterion is met.

C. Existing and proposed utility lines and easements.

Public Works Director Mike Miller states *"Currently both water and wastewater services have been installed and available to the lots."* This criterion is met.

D. Operational data explaining how the buildings and uses will function.

This site is proposed for a detached SUD and associated developments. The operation and function of these buildings are anticipated to be consistent with other single-unit residential uses. This criterion is met.

E. Any other pertinent information requested by the Planning Commission such as architectural renderings of the buildings and structures involved in the proposed development.

At the time of the writing of these Findings no additional information was requested by the Planning Commission.

F. Other information and format as required by FCC 10-1-1-4.

No other information has been determined to be necessary at the time of the writing of these Findings.

10-4-5: PUBLIC HEARING AND NOTICE: The Planning Commission shall hold at least one public hearing on each conditional use permit application.

A duly noticed public hearing was held by the Planning Commission on November 14, 2023. This public hearing was held prior to the issuance of any building permits on the subject site. This criterion is met.

10-4-6: ACTION: The Planning Commission shall make specific findings for granting or denying a conditional use permit in accordance with the general criteria and/or conditions of Section 10-4-9 of this Title.

During this review process the Planning Commission is making specific Findings for granting or denying this conditional use permit and temporary conditional use permit in accordance with the general criteria and conditions of FCC 10-4-9. This criterion is being satisfied as part of this review process.

10-4-7: EFFECTIVE DATE: A conditional use permit shall become effective at the close of the appeal period.

The Planning Commission held a hearing November 14, 2023. The Planning Commission shall make specific findings regarding the application for a conditional use permit according to the criteria as presented in these findings. Should the request for a conditional use permit be approved, it shall become effective at the close of the appeal period.

10-4-8: EXPIRATION OF CONDITIONAL USE PERMIT:

- A. Authorization of a conditional use permit shall be void one (1) year after the date of approval of a conditional use application, unless a building permit has been issued and substantial construction pursuant thereto has taken place. Substantial construction shall be considered to be completion of a building foundation. The applicant may apply to the Planning Commission for a one-time extension of one (1) year maximum duration based on compliance with the following criteria:**
 - 1. The request for an extension is made in writing prior to expiration of the original approval.**
 - 2. There are special or unusual circumstances that exist which warrant an extension.**
 - 3. No material changes of surrounding land uses or zoning has occurred. The Planning Commission may deny the request for an extension of a conditional use if new land use regulations have been adopted that affect the applicant’s proposal. (Ord. 26, 2008)**

This conditional use permit for a detached SUD in Mainstreet Area B Zoning district shall be valid for one year after the date of approval (November 14, 2024). In accordance with this code section, a request for extension shall be made in writing prior to the expiration or the original approval is substantial construction has not taken place.

Authorization of a conditional use permit shall be void one (1) year after the date of approval, November 14, 2024, unless a building permit has been issued and substantial construction pursuant thereto has taken place (Condition 6.1). See section FCC 10-4-11-H below for additional conditions imposed by the Planning Commission for completing construction of the dwelling.

B. The discontinuance of a conditional use for twelve (12) consecutive months shall constitute expiration of that conditional use. The use occupying the premises thereafter shall conform to the regulations of the zoning district in which it is located.

The discontinuance of the conditional use for 12 consecutive months or the intentional demolition or removal of the SUD shall constitute an expiration of this conditional use permit. and shall require a new conditional use permit to be obtained (Informational 8).

10-4-10: GENERAL CRITERIA: A conditional use permit may be granted only if the proposal conforms to all the following general criteria: (Ord. 669, 5-17-82)

A. Conformity with the Florence Comprehensive Plan

The Florence *Realization 2020 Comprehensive Plan* policies that apply to this project are Chapter 2 Residential uses Policy 9, Downtown Policy Planning Area Policy 1 Chapter 10 Policy 10, and Chapter 12 Policy 10. Each of these will be discussed separately.

Chapter 2: Land Use

Residential

9. The City shall permit a manufactured home to be located in any residential area in accordance with Oregon law, the provisions of the City’s zoning code and applicable building and specialty codes.

In accordance with this Comprehensive Plan policy the City shall permit a manufactured home to be located in a residential area in accordance with Oregon Revised Statute (ORS) 446.200. A manufactured home shall be constructed to minimum safety standards, but is not required to comply with additional regulations that are not applied to other dwelling types in the same zoning district.

Downtown Planning Area

Policy 1. To develop a unified downtown consisting of the neighborhoods and commercial districts on both sides of Highway 101, south of Highway 126 and 9th Street, east of Kingwood Avenue, and west of the Port property along the Siuslaw River estuary.

The subject property is located within the Downtown Planning Area. The adjacent properties are primarily detached single-unit dwellings. This unit will match with the existing residential character of the neighborhood. There are commercial properties to the east of the subject site that will allow for walkability to commercial services from the subject site. A residential unit on this site can add to the existing neighborhood and unified downtown area through both the location of the residential unit and the access to commercial services.

The variance request for an encroachment into the front yard setback serves to meet this Comprehensive Plan goal and policy as covered front porches and entries can improve the neighborhood feel of an area. The front porch, while not required, would also be in keeping with the character of the neighborhood as the predominate number of residences in the immediate area have covered porches. Additionally, the manufactured dwelling is required to have a front

porch due to minimum crawl space requirement that will be discussed in more detail under section FCC 10-5. The roof on the covered porch will not encroach into the front setback area more than an uncovered porch, which is a permitted structure in the front yard setback.

Chapter 10: Housing Opportunity

Policy 10. Apply plan designations, zoning districts and regulations to implement the mix of housing indicated in the acknowledge Housing Needs Analysis.

In accordance with FCC 10-27-5, detached single-unit residential units shall meet the development standards of Medium Density Residential districts.

Chapter 12: Transportation

Policy 10. Access to and from off-street parking areas shall be designed to prevent backing onto a public street (other than an alley), except for single-family duplex dwellings are exempt.

The applicant is proposing to place the driveway and carport structure in the rear setback and access on the alley. This will eliminate the need to back onto public streets as the lot design allows backing into the alley and pulling out head first on to the public street. While SUDs are exempt, this project is in compliance with this policy.

B. Compliance with special conditions established by the Planning Commission to carry out the purpose of this Chapter.

Special conditions of approval shall be established by the Planning Commission to carry out the purpose of this Chapter as well as the Florence Realization 2020 Comprehensive Plan. Review of the conditional use permit criteria and the policies of the Comprehensive Plan were previously reviewed. Conditions are included as necessary.

C. Findings that adequate land is available for uses which are permitted outright in the district where the conditional use is proposed. Available land can be either vacant land or land which could be converted from another use within the applicable zoning district. Land needs for permitted uses may be determined through projections contained in the Florence Comprehensive Plan or other special studies.

According to the [2018 Housing Needs Analysis](#), the Downtown Planning Area the majority of development and redevelopment is “expected to occur on smaller lots with a mix of commercial retail, office and upper-level residential uses... Overall redevelopment activity within the Florence UGB is expected to range from 46,000 to 53,000 square feet of infill/redevelopment (building floor area), which is over and above the vacant land needs shown in Exhibit VI.1” (pg. 38). According to the 2018 HNA the City has adequate downtown space for development and re-development. Additionally, the 1999 Downtown Implementation Plan states a goal for in-fill and redevelopment to allow residents to be in close walking distance of stores and services on Hwy 101. These criteria are met.

D. Conditional uses are subject to design review under the provisions of Chapter 6 of this Title, except single family and duplex residential use. (Ord. 625, 6-30-80) See Code Section 10-6-3 for Design Review requirements.

The proposed detached SUD use is exempt from Chapter 6 Design Review in accordance with this code section.

E. Adequacy of public facilities, public services and utilities to service the proposed development.

The public facilities, services, or utilities necessary to serve the proposed structure exist adjacent to the intended site and are adequate to serve the subject site and proposed use according to the referral comments of the Public Works Director (Exhibit D). This criterion is met.

F. Adequacy of vehicle and pedestrian access to the site, including access by fire, police and other vehicles necessary to protect public health and safety. (Ord. 669, 5-17-82).

The proposed site is accessible by both private and emergency vehicles. The site will have vehicle access from the alley to the west and driveway access from the alley. Pedestrian access will be available from the 7th Street ROW by means of a sidewalk to be installed as part of this project. In accordance with FCC 10-35-3-1 newly constructed sidewalks shall be constructed along all street frontage (7th Street) of the lot. A paved pedestrian walkway shall be installed for pedestrian access from the newly installed sidewalk to the dwellings front entrance (Condition 6.2). This criterion is met or is conditioned to be met.

10-4-11: GENERAL CONDITIONS: The Planning Commission may require any of the following conditions it deems necessary to secure the purpose of this Chapter. Where a proposed conditional use is permitted in another district, the Planning Commission may apply the relevant development standards from the other district. In addition, conditions may be required by the Design Review Board. Such conditions may include: (Ord 625, 6-30-80; amd. Ord 669, 5-17-82)

A. Regulation of uses, special yard setbacks, coverage and height.

Special front yard and rear yard setbacks (variance) are requested as part of this application. The special front yard setback is requested to allow for a covered porch, which will be beneficial in keeping with the general character of the neighborhood. The variance request for the rear yard setback is to allow for the required covered parking onsite. The variance requests are discussed in more detail under FCC 10-5.

No other regulations of use, lot coverage, or building height is proposed with this request.

B. Requiring fences, walls, screens and landscaping plus their maintenance.

Due to the orientation of the proposed on-site parking, screening of headlights along the west property line is required and has previously been conditioned under FCC 10-3.

C. Regulation and control of points of vehicular ingress and egress.

Vehicles will be able to access the proposed site using the existing alley on 7th Street between Maple and Laurel Streets. The site will have vehicle access from the existing alley. The alley is improved with pavement, but will require upgrades to the curb cut along the 7th Street frontage.

Accessing the property from the existing alley will also minimize the need for backing out maneuvers onto public ROWs. These criteria are met

D. Regulation of noise, vibration, odors, and sightliness.

The proposed project is a detached SUD. There is anticipated to be temporary noise, vibration, odors, and sightliness associated with construction, during the construction period only. FCC 10-6-1 regulations to nuisances will apply to this project as with any residential use in the Mainstreet Area B zoning district (Informational 1).

At all times during construction and while the temporary construction site dwelling is located on the subject site the property shall be maintained in a manner that is compliant with FCC 6-1-8 which regulates nuisances within City Limits (Condition 6.7).

For the purpose of this review process both Lot 5601 and 5601 are considered a single project site. This is to allow for development of Lot 5602 with the SUD and associated development and siting of the temporary construction site dwelling. However only Lot 5602 is proposed to be developed at this time. Therefore, within 3 calendar days following final inspection approval Lot 5601 shall be cleared of all items, material, structures until such time this lot has an approved use through City land use approval process (Condition 6.10).

This criterion is or is conditioned to be met.

G. Regulation of hours of operation and duration of use or operation.

Regulation of hours of operation are not applicable with this application as the proposed use is a single unit residential use.

H. Requiring a time period within which the proposed use shall be developed.

The Planning Commission, at their discretion, has included as a condition of approval that construction and installation of the proposed dwelling shall have final approved inspection within 180 days following the close of the appeal period. If final improved inspections are not completed within this time period an application shall be submitted in accordance with FCC 10-4-8-A (Condition 6.9). This criterion is conditioned to be met.

I. Requiring bonds to insure performance of special conditions.

The proposed use is typical of a residential use and zoning and does not create circumstances where regulation of these criteria (FCC 10-4-11-D through I) are warranted with additional conditions of approval.

J. Regulation of tree and vegetation removal to maintain soil stability, preserve natural habitat, protect riparian vegetation, buffer conflicting uses, and maintain scenic qualities.

The subject lot is vacant and does not include riparian areas, significant slopes, or buffers with conflicting uses. The existing site is vacant and mostly cleared of vegetation. No regulation of tree and vegetation removal is necessary to maintain soil stability.

- K. Such other conditions as will make possible the development of the City in an orderly and efficient manner and in conformity with the intent and purpose of the Florence Comprehensive Plan.**

The proposed use is consistent with the Florence Comprehensive Plan, as discussed above, and will not prevent the orderly and efficient development of the City. These criteria were previously discussed.

10-4-12: ADDITIONAL CONDITIONS: Some land uses by the nature of the activity associated with them require separate and intense consideration by the Planning Commission prior to their establishment. Such uses and additional conditions are as follows:

E. Temporary Mobile Building Space:

- 3. Temporary Construction Site dwelling: A conditional use permit may be issued for a temporary construction site dwelling on sites with an active grading or building permit, provided the following requirements are met:**
- a. The Temporary Construction Site dwelling may take the form of an RV, park model or similar structure.**

The proposed temporary construction site dwelling is an RV. This criterion is met

- b. The dwelling may not occupy public right-of-way or obstruct sidewalks.**

The exact site of the temporary construction site dwelling has not been determined. At no time shall the temporary construction site dwelling occupy or obstruct public sidewalks, ROW or alleys (Condition 6.3). This criterion is met or is conditioned to be met.

- c. The dwelling may be occupied either by the property owner or by a person or persons who will be principally engaged in construction associated with an active grading or building permit on-site.**

The dwelling is proposed to be occupied by the property owner. This criterion is met.

- d. One dwelling is permitted per site.**

A single construction dwelling for the project site is proposed. This criterion is met.

- 1. Dwellings must be located on the site where construction is taking place.**

[...]

Both lots are owned by the applicant and are determined to be a single site for the purposes of this application review. The portion of the site that is proposed for development is the eastern most lot (Lot 05602). The western most portion of the site is vacant and proposed to remain vacant following construction of the residential unit and associated development (Lot 05601).

These lots are each 60' long x 42' wide = 2,520 square feet.

The lot proposed to be developed with the dwelling is not large enough to accommodate the construction work, proposed structures, and the temporary construction site RV dwelling. Therefore, the temporary construction site dwelling will be sited on the adjacent and contiguous tax lot, which is part of the overall proposed site for the purpose of this temporary conditional use permit.

As previously discussed, there are two tax lots present, but the site is considered to be both tax lots for the purposes of review of this application. Therefore, the temporary construction site dwelling may be sited on either tax lot 5602 or 5601. This criterion is met.

- e. Dwellings may not occupy the setbacks of the base zone or any other applicable setbacks.**

The exact location of the temporary construction site dwelling has not been finalized. In accordance with this section the dwelling shall not occupy required setbacks of the lot (Condition 6.3). This criterion is conditioned to be met.

- f. Construction shall not prevent the removal of a Temporary Construction site dwelling.**

The sole driveway access for this site is from the alley along the eastern property line. To allow the temporary RV construction site dwelling to be removed from the site, it shall be removed prior to construction and installation of the carport structure. The RV is permitted to be used as a temporary construction site dwelling only (Condition 6.4). Residing in this unit after the approved period shall not be permitted. This approval does not permit storing of the RV on the vacant site following construction beyond what is currently permitted in code (Informational 2). This criterion is conditioned to be met.

- g. Temporary Construction Site dwellings must be removed prior to the issuance of a Certificate of Occupancy. A Certificate of Occupancy will not be issued until the dwelling is removed. For projects where no Certificate is issued, then the dwelling must be removed within 3 days of final inspection approval.**

In accordance with this code section the temporary construction site dwelling shall be removed from the site (Lots 5602 and 5601) within 3 calendar days of final inspection of the dwelling unit (Condition 6.8). At the discretion of the Planning Commission the condition for removal within 3 days of final approved inspection rather than issuance of Certificate of Occupancy has been imposed. This criterion is conditioned to be met.

TITLE 10: CHAPTER 5: ZONING ADJUSTMENTS & VARIANCES

10-5-2: LIMITATIONS: An adjustment or variance shall not be granted as a substitute for, or in lieu of, a change in zone. An adjustment or variance does not apply to use regulations

- B. Variances: Requests to vary standards beyond the adjustments allowed in Section 10-5-2-A shall be subject to the review process and approval criteria for variances. The Planning Commission may grant a variance to a regulation through the Type III Review process in Section 10-1-1-6-3 as prescribed by this Title with respect to the following:**

[...]

3. Front, side or rear yards.

[...]

9. Any request to vary numerical standards beyond 10%

In conjunction with the CUP for allowing a SUD in the MSB Zoning District, a variance for up to 5 feet in the front yard setback (7th Street) and rear yard setback (south property line) is being requested to allow for a covered entrance to be constructed if the applicant desires and to decrease the rear yard setback to permit sitting of the required covered parking on site.

This request represents a request to vary numerical standards beyond 10% and is therefore a variance request rather than an adjustment.

This request requires approval and review by the Planning commission through a Type III review process. The Planning Commission is being tasked with review and decision regarding the variance requests for a decreased front and rear yard setback. This criterion is being met through this review process.

10-5-3: APPLICATION:

B. The application for variance shall be made in writing to the Planning Commission by the owner(s) of the land in consideration or their agent(s), duly authorized in writing.

An application is not being made by the applicant, but rather initiated by City staff due to the size constraints of the lot. This criterion is met.

10-5-4: APPROVAL CRITERIA: A. General: An application for an adjustment or variance must describe in detail:

1. The practical difficulties and physical hardships involved.

The dimensions of the lot proposed for development are 42'x 60' which meet the district standards. When combined with the required setbacks they create a physical hardship for the applicant and property owner. The available development building pad on the lot for a dwelling is 15 ft. by 50 ft. To locate a manufactured home on the site a very small structure must be chosen. A stick-built structure would likely need a variance also. In 2005 an applicant received setback variances for a 16 ft. wide dwelling in the Mainstreet District. While the district supports dense development some of the historic lot dimensions are challenging to construct to with today's land use, building and HUD building codes. The detached SUD and the required development structures (covered porch and parking structure) cannot fit on the site without a variance for reduced setbacks. The site dimension poses unique physical hardships to develop the subject site that are beyond the control of the applicant. This criterion is met.

2. Existing conditions on the site.

The existing conditions of the site have previously been described in these Findings. This criterion is met.

3. Reasons for the proposed adjustment or variance being the most practicable solution to the problem.

Below are the main reasons that the proposed variance is the most practical solution to the problem. The front yard setback is discussed first and the rear yard setback second.

1. FCC 10-2-3-A permits certain structures in the required front yard which includes “steps, platforms, and porches having no roof covering and being not over 3 ½ feet in height.” As the applicant is proposing a manufactured home it will likely require stairs to enter and possibly a railing on the stairs for safely entering the home. A stair railing for safety may exceed 3 ½ feet in height and therefore would not otherwise be permitted without a variance. The stairs and porch are permitted in the front yard setback. The proposed variance is for a covered porch and stair railing encroachment in the front yard setback. Permitting the variance at this time would decrease delays and costs to the applicant to install these features after selecting the manufactured home.
2. A front porch would be an architectural element to add aesthetic and visual interest while keeping with characteristic of the existing neighborhood. A covered front porch would add a break in the long expanse of the 7th St. building frontage and add an architectural element in accordance with FCC 10-6-3.
3. The 1999 Florence Downtown Implementation had a vision for the subject neighborhood to maintain development patterns through parking located behind buildings and maintain front setbacks from 5 to 10 feet.

In accordance with FCC 10-2-3-A, structures that are permitted in a front yard setback include “platforms and porches having no roof and no over three and one-half (3 ½’) high may be built in the front yard.” Due to the dimensions of the subject lot, there is not adequate space for both the manufactured dwelling and a covered porch without encroaching into the front yard. The available width of the building pad is 15 ft. with the required setbacks. The uncovered porch is permitted in the front yard setback and will be required to enter the home. In accordance with the [2010 Oregon Manufactured Dwelling Installation Specialty Code](#), section 3-5.1 the minimum foundation height is 18” for 75% of the under-floor crawl space. See below.

3-5 Clearance Under Homes.
3-5.1 Minimum Foundation Heights.
Manufactured dwellings shall have the following minimum foundation heights. See Figure 3-5.1.
(1) 75 percent of the under-floor crawl space of a manufactured dwelling shall be at least 18 in. in height between the underside of the main frame and the top of the footing or slab.
(2) No area under the chassis main frame shall have a clearance less than 12 in. between the underside of the main frame and the top of the footing.

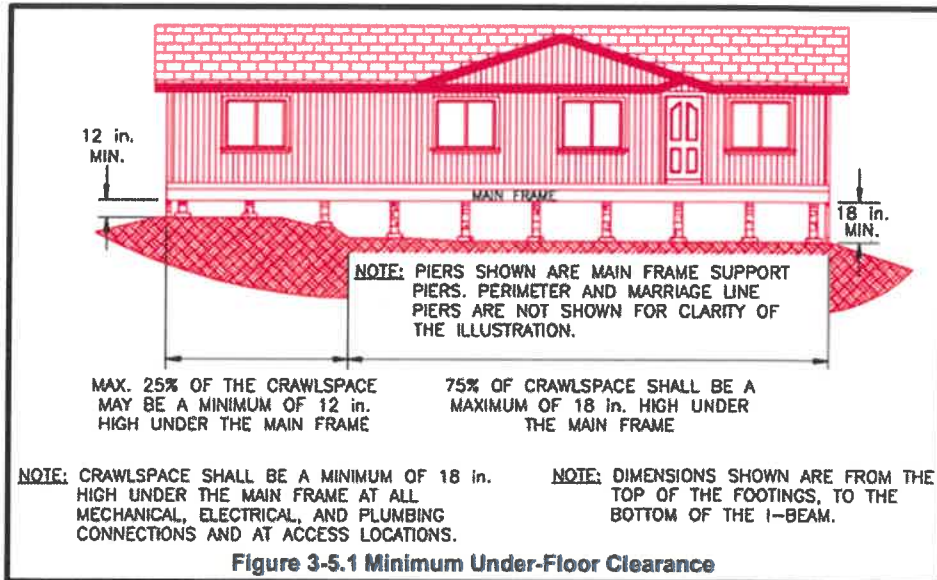

The rear yard setback variance is being requested to address the hardship created by the required garage/carport rear lot line setback requirement. If strict adherence to this rear yard setback was required the dwelling building pad would be reduced to 10 ft. wide. There are no HUD qualified homes that meet this dimension. The narrowest dwelling in Florence is 16 ft wide. The alternative is to request a variance for on-site parking. required under FCC 10-3-8. The proposed parking location to the rear of the building is in keeping with the 1999 Downtown Implementation Plan that states a goal for “off-street parking located behind buildings.”

Below is an image of the proposed site plan (Exhibit C) that illustrates the maximum 15 x 50 feet building pad. This site plan includes the required 10-foot front yard setback, 5-foot rear yard setbacks, and the proposed 5-foot rear yard setback. Below the site plan is an example of a 13' 6" x 48 foot manufactured home floor plan from [Factory Direct Homes](#) as an example of a unit that may fit on this site.

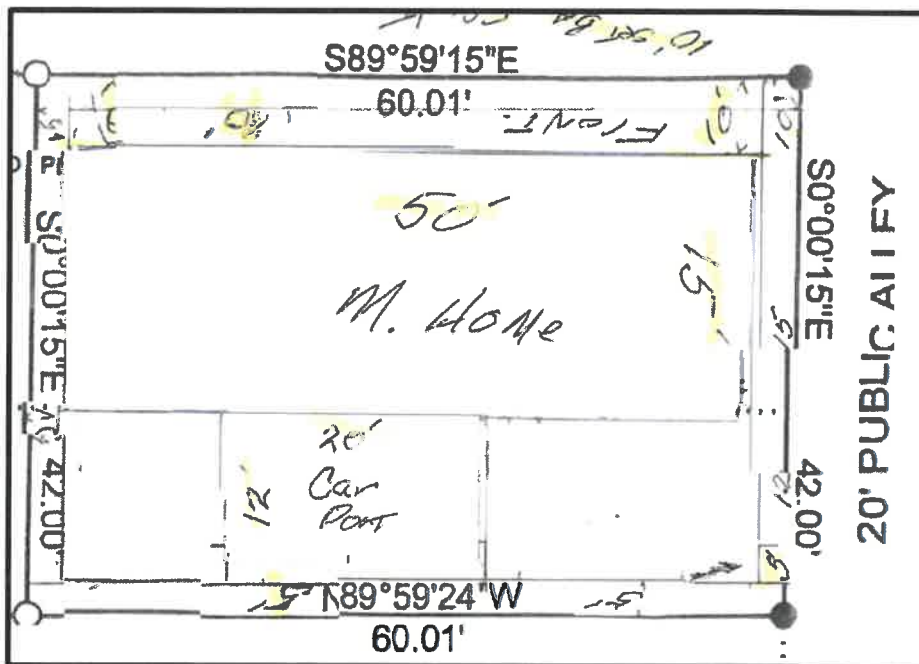

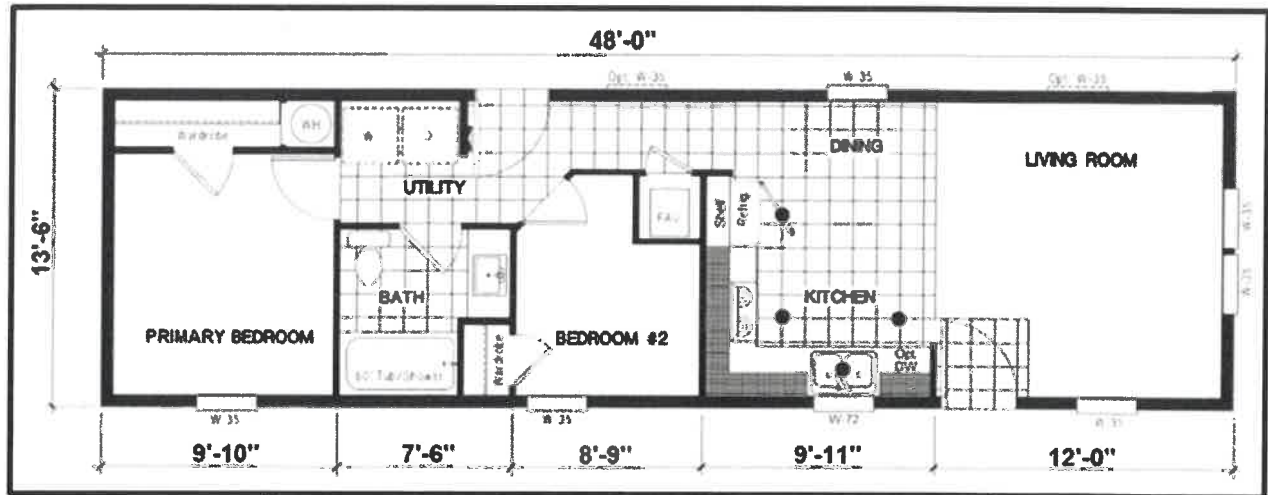

DREAM SILVER SERIES 14x48 DRM 481M
2 BEDROOM, 1 BATH - 648 SQ. FT.

The required rear yard setback is 5 feet from all structures except it is 10 feet from a garage or carport. This is intended for a garage that is accessed from the front of the lot to provide a 10-foot buffer between the rear garage and the adjacent property. This setback is not intended for the side of the carport to the rear lot line. The rear lot line variance is the most practical solution for the following reasons:

1. The location of the driveway and parking in the rear yard is preferable to maintaining the character of the community and not having vehicle parking and storage the main visual element of the dwelling.
2. The proposed location will minimize or eliminate backing out movements on to the public ROW which will maintain pedestrian and vehicular safety.
3. The required 10-foot setback for the proposed layout of this site is an unintended consequence of the code. The rear wall of the carport will have a 10-foot setback from the adjacent property line, which is the intent of this code requirement. The proposed 5-foot setback will allow for adequate fire and life safety access to the site.
4. This variance does not provide special privilege to the property owner, but rather serves to correct an area in the code where an unintended consequence has occurred causing a hardship to the property owner,

A variance is the most practical solution for the hardships of the rear and front yard setbacks present on this site. The front yard setback variance is required due to the dimension constraints of a manufactured home and shall only be granted if the site is developed with a single-unit detached manufactured dwelling (Condition 6.5). In keeping with the intent of the minimum 10-foot rear yard setback under FCC 10-10-4-D, the carport shall have a minimum 10-foot setback from the west property line (Condition 6.6). This criterion is met.

4. **A sight plan, drawn to scale, showing the dimensions and arrangement of the proposed development in comparison to the existing standard(s).**

A site plan drawn to scale containing all required information was submitted as part of this application. This criterion is met.

- 5. Any other pertinent information requested by the Planning Director or Planning Commission.**

No additional information was requested by the Planning Director or the Planning Commission at the time of the writing of these Findings.

- B. Variances shall be reviewed through a Type III process in accordance with requirements of Section 10-1-1-6-3 of this Title.**

This variance request is being reviewed through a Type III process in accordance with this Code section and FCC 10-1-1-6-3. This criterion is met.

10-5-6: EFFECTIVE DATE: An adjustment or variance shall become effective at the close of the appeal period. 10-5-7: EXPIRATION OF ADJUSTMENT OR VARIANCE:

- A. Authorization of an adjustment or variance shall expire concurrently with its associated land use approval or one (1) year after the date of approval of an application, whichever is greater, unless a building permit has been issued and substantial construction pursuant thereto has taken place. Substantial construction shall be considered to be completion of a building foundation. The applicant may apply to the Planning Commission for a one-time extension of one (1) year maximum duration based on compliance with the following criteria:**
- 1. The request for an extension is made in writing prior to expiration of the original approval**
 - 2. There are special or unusual circumstances that exist which warrant an extension**
 - 3. No material changes of surrounding land uses or zoning has occurred.**
- B. The Planning Commission may deny the request for an extension of a variance if new land use regulations have been adopted that affect the applicant's proposal. (Ord. 26, 2008)**

This code section is included as a reference for extension request requirements. The variance shall be valid for 1 year (November 14, 2024) unless a building permit or substantial construction has taken place (Informational 3).

TITLE 10: CHAPTER 10: RESIDENTIAL DISTRICTS

10-10-4: LOT AND YARD PROVISIONS:

- A. Minimum Lot Dimensions: To be designated a building site, a lot must meet the following minimum lot dimensions:
Table 10-10-4-A. Minimum lot dimensions by Development Type.**
- B. Minimum Lot Area: To be designated a building site, a lot must meet the following minimum lot area:**

This lot is in MSB and is regulated by maximum lot coverage in accordance with FCC 10-27-4-B. This will be discussed in detail under that Code section.

C. Lot Coverage: The maximum coverage shall not exceed the following:

This lot is in MSB and is regulated by maximum lot coverage in accordance with FCC 10-27-4-C. This will be discussed in detail under that Code section.

D. Yard Regulations: Unless an adjustment or variance is granted in accordance with Chapter 5 of this Title, minimum setbacks and yard regulations shall be as indicated below:

Table 10-10-4-D. Minimum setbacks and yard regulations.

	LDR	MDR	RMH	HDR
Front				
Primary	10 ft.	10 ft.	10 ft.	5 ft. ¹
Garage or Carport vehicular entrance wall	20 ft.	20 ft.	20 ft.	20 ft.
Side				
Primary ²	10 ft.	5 ft.	5 ft.	5 ft. ¹
Accessory Building	5 ft.	5 ft.	5 ft.	5 ft.
Accessory Dwelling Unit	10 ft.	5 ft.	5 ft.	5 ft.
Parking Lot, Garage or Carport	10 ft.	5 ft.	5 ft.	5 ft.
Garage or Carport vehicular entrance wall	20 ft.	20 ft.	20 ft.	20 ft.
Rear¹				
Primary	10 ft.	5 ft.	5 ft.	5 ft. ¹
Accessory Building	5 ft.	5 ft.	5 ft.	5 ft.
Accessory Dwelling Unit	10 ft.	5 ft.	5 ft.	5 ft.
Parking Lot, Garage or Carport	10 ft.	10 ft.	10 ft.	10 ft.
Garage or Carport vehicular entrance wall	20 ft.	20 ft.	20 ft.	20 ft.
¹ Single-unit detached and duplex dwellings in the HDR District shall have the same front, side and rear yard regulations as the MDR District. ² Minimum side setbacks may be reduced to zero feet (0') for attached primary structures where they share a common wall with a structure on an adjacent lot. ³ For a corner lot or parcel which adjoins the point of intersections of two streets as defined in "Lot Type Corner" both lot or parcel lines are the front line. The sum of these setbacks shall not fall below the sum of the minimum front and side yard requirements for primary building and no setback shall be below the minimum primary side yard requirement for the district.				

As previously discussed, this application is requesting a front and rear yard setback variance. The reasons for this were previously discussed under FCC 10-5. Side yard setbacks are indicated to be met as seen on Exhibit C and will be reviewed for compliance at the time of building plan review.

10-10-5: SITE DEVELOPMENT PROVISIONS:

A. Building or Structural Height Limitations:

1. **Primary Structures:** The maximum building or structural height shall be thirty-five feet (35'), excepting High Density District which shall permit forty feet (40'), limited to three (3) stories.
2. **Accessory Structures:** The maximum building height shall be twenty feet (20').
3. **Accessory Dwelling Units:** The maximum building height shall be twenty-eight feet (28').
4. **Nonresidential Structures:** The maximum building height shall not exceed thirty feet (30').
5. **Structures in the HDR, LDR, MDR and RMH shall have a minimum roof pitch of 3/12, except mobile homes in the mobile/manufactured home parks or district.**

As previously discussed, detached SUDs are exempt from design review. However, the dwelling and carport shall meet site development provisions as outlined in the code section. The applicant is proposing a single story manufactured home and a carport to meet FCC 10-3-8 covered parking requirements. Neither structure is anticipated to reach or exceed maximum heights. Compliance with these site development provisions shall be reviewed for compliance during building plan review (Informational 4).

B. Fences: See Code Section 10-34-5 of this Title

No fences are proposed as part of this project application.

C. Vision Clearance: Refer to Section 10-2-13 and 10-35-2-14 of this Title for definition, and requirements.

Vision clearance will be discussed under section FCC 10-35 of this Title.

D. Off-Street Parking: Refer to Chapter 3 of this Title (Off-Street Parking and Loading)

Off street parking was previously discussed under section FCC 10-3 of this Title.

[...]

G. Access and Circulation: Refer to Section 10-35 of this Title for requirements.

Access and circulation will be discussed under section FCC 10-35 of this Title.

H. Public Facilities: Refer to Section 10-36 of this Title for requirements.

Public Facilities will be discussed under section FCC 10-36 of this Title.

I. Lighting: Refer to Section 10-37 of this Title for requirements.

Lighting will be discussed under section FCC 10-37 of this Title.

10-10-10: MANUFACTURED HOMES OUTSIDE OF MH SUBDIVISIONS OR PARKS When a manufactured home is placed outside of a manufactured home subdivision or mobile home park in a zone which allows single unit dwellings, in addition to any other requirements that would be imposed were the structure constructed on site, the manufactured home shall comply with the following placement standards:

- A. Foundation:** The manufactured home shall be placed on an excavated and back-filled foundation and skirted in conformance with the requirements of the Building Codes Agency Manufactured Dwelling Administrative Rules in effect at the time of construction.
- B. Roof Pitch:** The manufactured home shall have a pitched roof with a nominal slope of at least three feet (3') in height for each twelve feet (12') in width.
- C. Thermal Performance:** The manufactured home shall be certified by the manufacturer to have an exterior thermal envelope meeting performance standard which reduce heat loss to levels equivalent to the performance standards required of single family dwellings constructed under the State Building Code as defined in ORS 455.010.

As previously discussed, the dwelling is proposed to be a manufactured home. The specific model has not been determined at this time. There are additional constraints to development that a manufactured home has that a site-built home may not. These constraints include the limited dimension options and the required crawl space, and therefore the requirement for a deck.

The additional constraints of the manufactured home and lot dimensions does not eliminate the development standards of this Code section. The development and sitting of the manufactured home shall meet the requirement of this Code section for foundation, roof pitch, and thermal performance (Condition 7.1). These items shall be reviewed for code compliance at the time of building plan review. These criteria are conditioned to be met.

TITLE 10: CHAPTER 27: MANSTREET DISTRICTS

10-27-3 Buildings and Uses Permitted Conditionally

The Planning Commission, subject to the procedures and conditions set forth in Chapter 4 of this Title, may grant a conditional use permit for the following:

- [...]
- k. Single unit detached dwellings**
- [...]

This project is a request to site a detached single-unit dwelling (SUD) in Mainstreet Area B, which is a use that may be permitted conditionally subject to Planning Commission approval of a conditional use permit. This is being satisfied through this review process.

10-27-4 Lot and Yard Dimensions

- A. Minimum Lot dimensions:** The minimum lot width shall be 25'.

The subject lot, Lot 05602, that is proposed to be developed with the detached SUD is lot is 42 feet x 60 feet. This lot meets minimum dimensions. This criterion is met.

B. Minimum Lot Area: The minimum lot area shall be 2500 square feet.

The subject lot, Lot 05602, that is proposed to be developed with the detached SUD is 2,520 square feet.

$$42 \times 60 = 2,520 \text{ sq. ft.}$$

This site meets the minimum lot square footage. This criterion is met.

C. Lot coverage: The Design Review Board may allow up to a maximum of 90% lot coverage by buildings and other impervious surfaces

Maximum lot coverage in MSB is 90% for coverage by buildings and other impervious surfaces. The submitted site plan indicates a maximum 39.3% lot coverage by buildings, which is below the maximum allowed.

Building	Width	Length	Total Sq. ft.
Dwelling	15	50	750
Carpport	12	20	240
Total Coverage by buildings:			990 sq. ft

$$990 / 2520 = 0.392 \text{ or } 39.3\%$$

Maximum lot coverage by all impervious surfaces may be up to, but not exceed 2,268 sq ft

$$2520 \times 0.90 = 2,268 \text{ sq. ft.}$$

This property is not anticipated to reach maximum lot coverage with the site proposed. Final calculation will be review for code compliance at time of building plan review, but are anticipated to be below maximums allowed (Informational 6). This criterion is met.

D. Yard Regulations: Area “B”: Single unit detached residential uses shall meet the standards of the Medium Density District. Multi-units shall meet the standards of the High Density District. Conversion to mixed use or commercial use shall conform to Mainstreet District standards, except that the 20’ height requirement does not apply.

In accordance with this Code section this proposed project for a detached SUD shall meet the yard regulations of MDR as it relates to yard regulations. These criteria were previously discussed under FCC 10-5 relating to the variance requests for decreased rear and front yard setbacks.

10-27-5 Site and Development Provisions

A. Building or Structural Height Limitations

[...]

Area “B”: Single unit detached residential uses shall meet the standards of the Medium Density District. Multi- units shall meet the standards of the High Density District.

Conversion to mixed use or commercial use shall conform to Mainstreet District standards.

In accordance with this Code section this proposed project for a detached SUD shall meet the standards of MDR as it relates to building or structural height limitations. These criteria were previously discussed under FCC 10-10.

[...]

C. Fences, Hedges, Walls and Landscaping: Landscaping shall be in accordance with FCC 10-34, except as modified by the following specific standards.

[...]

Area “B”:

Single unit detached residential uses shall meet the standards of the Medium Density District. Multi-unit units shall meet the standards of the High-Density District. Conversion to mixed use or commercial use shall conform to Mainstreet District standards.

In accordance with this Code section this proposed project for a detached SUD shall meet the standards of MDR as it relates to fences, hedges, walls, and landscaping. These criteria were previously discussed under FCC 10-10.

C. Access and Circulation. Refer to Section 10-35 Access and Circulation of this Title for Requirements.

- 1. Access Management Plan: All access points to Highway 101 shall be governed by the Access Management Plan for Highway 101 in Downtown Florence.**
- 2. Sidewalks abutting buildings on Highway 101, Highway 126, and local streets within the Mainstreet District shall be at least 8’ in width, except collector streets within the Mainstreet District without on-street parking as described below. Sidewalk area beyond the standard 6’ sidewalk width may be surfaced with pavers, brick or other similar materials. Maintenance and repair of pavers, brick, etc. are the responsibility of the business/property owner.**
 - a. Sidewalks on collector streets within the Mainstreet District may be reduced to 6’ in width with 6’ of clear walkway if there is no on-street parking on that side of the street.**
- 3. Access to all floors of all commercial buildings and structures shall meet ADA requirements.**

D. Parking and Loading Spaces

[...]

Area “B”:

Single unit residential uses shall meet the standards of the Medium Density District. Multi-unit units shall meet the standards of the High-Density District. Conversion to mixed use or commercial use shall conform to Mainstreet District standards, except that the 20' height requirements do not apply.

E. Vision Clearance. Refer to Section 10-1-14 and 10-35-2-13 of this Title for definitions and requirements.

Vision clearance shall be discussed under section FCC 10-35-2-13.

F. Signs. Shall be in accordance with Title 4 Chapter 7 of this Code. (Ord. 4, 2011)

No signs are proposed or anticipated for this residential use. This criterion is not applicable.

G. Lighting. Street lighting, building lighting and lighting of parking lots and walkways shall conform to the following lighting standards:

- 1. Light fixtures shall conform to the lighting styles in the Architectural Guidelines.**
- 2. Lighting shall be pedestrian scaled.**
- 3. Refer to Section 10-37 of this Title for additional requirements.**
- 4. Wiring for historic fixtures shall be underground. Other overhead wiring shall be placed underground, where possible.**

The site shall meet the requirement for lighting and light fixtures in accordance with this code section. Lighting fixtures shall be reviewed at time of building plan review (Condition 8.1). Additional lighting criteria will be discussed further under section FCC 10-37. This criterion is conditioned to be met.

H. Design Review.

All uses except single unit detached and residential duplex units shall be subject to Design Review criteria to insure compatibility and integration with the Mainstreet character, and to encourage revitalization. Architectural design shall be reviewed against the Downtown Architectural Guidelines to determine compatibility, with the exception of solar photovoltaic and solar thermal energy systems as allowed by HB3516.

In accordance with this code section the proposed detached SUD is not subject to design review. The proposed dwelling is required to meet development standards of FCC 10-10-5 and manufactured home standards of FCC 10-10-10. These criteria have previously been discussed.

I. Trash Enclosures.

All trash enclosures shall be located in side or rear yards, and shall be screened from street or pedestrian courtyard view with a permanent solid fence or wall at least 6' high. Service shall be from an abutting alley or interior parking lot where possible. Gates opening to non-street faces may be slatted chain link.

A trash enclosure in compliance with this code section shall be installed on-site prior to issuance of Certificate of Occupancy. This shall be included on the site plan for review at time of building permit review for review of location, enclosure height and materials (Condition 8.2). This criterion is conditioned to be met.

J. General Provisions.

1. **Outdoor storage of materials and display of merchandise for sale shall be subject to approval by the Design Review Board.**
2. **Where there is manufacturing, compounding, processing or treatment of products for wholesale, the front twenty-five (25) feet of the building's ground floor facing the principal commercial street shall be used for commercial sales, business or professional offices.**
3. **Any use allowed must not cause unreasonable odor, dust, smoke, noise, vibration or appearance.**

The proposed use as a detached SUD is anticipated to be compatible with adjacent uses and is not anticipated to cause unreasonable odor, dust smoke, noise, vibration, or appearance. FCC 6-1 relating to Police Regulations and General Offenses shall apply to the subject site as other properties within the City (Informational 1).

As previously discussed, the site shall be maintained or brought into compliance with both this code section This criterion is met.

K. Public Facilities: Refer to Section 10-36 of this Title for requirements

Public Facilities will be discussed under section FCC 10-36.

TITLE 10: CHAPTER 34: LANDSCAPING

10-34-5: FENCES AND WALLS: Construction of fences and walls shall conform to all of the following requirements:

- A. **General Requirements. All fences and walls shall comply with the height limitations of the respective zoning district and the standards of this Section. The City may require installation of walls and/or fences as a condition of development approval, in accordance with land division approval, approval of a conditional use permit, or design review approval. When required through one of these types of approvals, no further land use review is required. (See also, Section 10-34-3-6 for landscape buffering and screening requirements.)**
- B. **Dimensions.**
 1. **Residential Zones: Except as provided below, the height of fences and walls between the building and the front lot line shall not exceed four (4)feet as measured from the grade and no greater than 6 feet in height in rear and side yards unless the front door is located on the longer side of the lot, in which case the fence shall not exceed four (4) feet in height or taller fences or walls**

are allowed through a Type II or III Design Review approval. (See Figure 10-34(2))

2. **Commercial and Industrial Zones:** Except as provided below, the height of fences and walls in any required front yard shall not exceed four (4) feet as measured from the grade and no greater than eight (8) feet elsewhere on site.

No fences are proposed as part of this application. This section was included for reference for permitted fence criteria and requirements. There is one existing fence on the south (rear) property line that is not part of this application.

TITLE 10: CHAPTER 35: ACCESS AND CIRCULATION

10-35-2-2: Applicability: Section 10-35-2 applies to vehicle access and on-site circulation facilities in the City of Florence. This Section applies to any type of land use or development permit. Access to a designated state or county highway is subject to the provisions of this Section in addition to the requirements of the applicable roadway authority. Where regulations of the City conflict with those of the roadway authority the more restrictive requirements apply.

This application represents a land use permit and therefore the applicable Code criteria of FCC 10-35 applies.

10-35-2-3: Access Approval Required: Access will generally be reviewed in conjunction with a land division or building permit. If a property owner wishes to access a public street (e.g., a new curb cut or driveway approach), or make improvements within the public right-of-way (e.g., install or replace sidewalk), the property owner must obtain a "Construction Permit in Right-of-Way". In either case, approval of an access shall follow the procedures and requirements of the applicable road authority.

This site takes access from an alley on the east side of the site and accesses local 7th Street from the alley. Therefore, approval from local City authority. The City of Florence Public Works department was sent a referral request on October 26, 2023. According to Public Works Director Mike Miller *"the alley approach does not meet current design criteria for ADA accommodations, therefore the City will replace the alleyway way approach reconstruction"* (Exhibit D). A work in the right-of-way permit shall be obtained from the City of Florence Public Works Department before any work may begin in a public ROW (Informational 5). This criterion is met.

10-35-2-6: Conditions of Approval: The roadway authority may require the closing or consolidation of existing curb cuts or other vehicle access points, recording of reciprocal access easements (i.e., for shared driveways), development of a frontage street, installation of traffic control devices, and/or other mitigation as a condition of granting a land use or development approval or access permit, to ensure the safe and efficient operation of the street and highway system. **10-35-2-7: Intersection Separation; Backing onto Public Streets:** New and modified accesses shall conform to the following standards:

- A. Except as provided under subsection B, below, the distance from a street intersection to a driveway shall meet the following minimum spacing requirements for the street's classification, as measured from side of driveway to street or alley pavement (see Figure 10-35(1)). A greater separation may be required for accesses onto an arterial or collector for compliance with ODOT or County requirements.

Separation Distance from Driveway to Pavement:

Alley	15 feet
Local Street	25 feet
Collector Street	30 feet
Arterial Street	50 feet

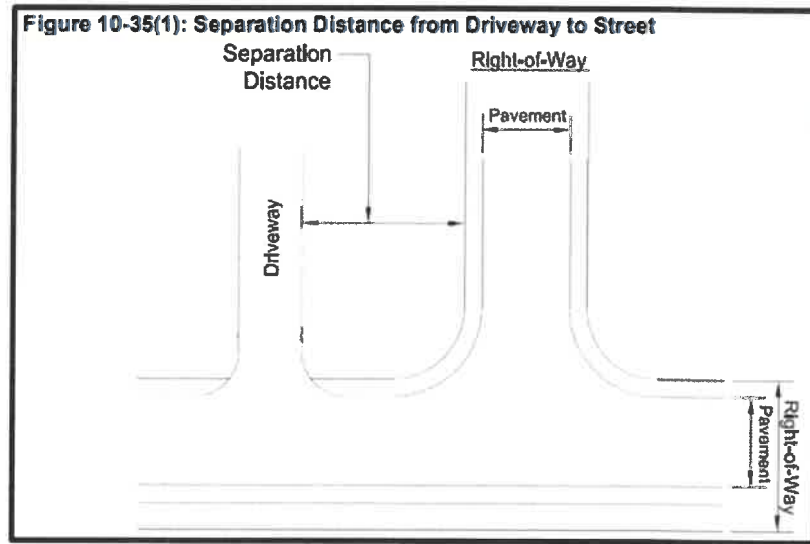

The driveway access on the alley is proposed is 25 feet from the 7th Street pavement. The 25 feet proposed exceeds the minimum required 15 feet of separation. This is significant to the variance request for the decreased rear yard setback as driveway cannot be placed within the first fifteen feet from the front property line. As previously discussed, the lot does not have dimensions to accommodate driveway access from the front of the lot (7th Street ROW). The location for a driveway that maximizes buildable space on site is at the rear of the lot off the alley. This criterion is met.

[...]

- C. Access to and from off-street parking areas shall be designed to prevent backing onto a public street, except that single-unit detached and attached and duplex dwellings are exempt on streets classified local.**

As previously discussed, this proposed detached SUD is exempt from the requirement preventing backing movements onto public streets. However, the site taking access from the alley will provide opportunities to access the site without requiring backing movements onto the street. This criterion is met.

10-35-2-8: Access Standards: New development shall gain access primarily from local streets. Access onto arterials and collectors shall be evaluated based on access options, street classifications and the effects of new access on the function, operation and safety of surrounding streets and intersections and possible lower level street alternatives. Where such access to higher level street classification is necessary, shared driveways

may be required in conformance with FCC 10-35. If vehicle access off a lower-level street is possible, then the City may prohibit access to the higher-level street.

This project represents new development and therefore shall take access primarily from a local street. This site proposed taking access from an alley and then to a local street. This criterion is met.

10-35-2-12: DRIVEWAY DESIGN: All openings onto a public right-of-way and driveways shall conform to the following:

- A. Driveway Approaches.** Driveway approaches, including private alleys, shall be approved by the Public Work Director and designed and located with preference given to the lowest functional classification street. Consideration shall also be given to the characteristics of the property, including location, size and orientation of structures on site, number of driveways needed to accommodate anticipated traffic, location and spacing of adjacent or opposite driveways
- B. Driveways.** Driveways shall meet the following standards, subject to review and approval by the Public Works Director:
 - 1. Driveways for single family residences shall have a width of not less than ten (10) feet and not more than twenty-four (24) feet.**
 - 2. Driveways shall have a minimum width of ten (10) feet, except where a driveway serves as a fire apparatus lane, in which case city-approved driveway surface of 12 feet minimum width shall be provided within an unrestricted, twenty (20) foot aisle, or as approved by the Fire Code Official.**
 - 5. The maximum allowable driveway grade is fifteen (15) percent, except that driveway grades exceeding fifteen (15) percent may be allowed, subject to review and approval by the Public Works Director and Fire Code Official, provided that the applicant has provided an engineered plan for the driveway. The plan shall be stamped by a registered geotechnical engineer or civil engineer, and approved by the Public Works Director.**
- C. Driveway Apron Construction.** Driveway aprons (when required) shall be constructed of concrete and shall be installed between the street right-of-way and the private drive, as shown in Figure 10-35(2) (pictured on next page). Driveway aprons shall conform to ADA requirements for sidewalks and walkways, which generally require a continuous unobstructed route of travel that is not less than three (3) feet in width, with a cross slope not exceeding two (2) percent, and providing for landing areas and ramps at intersections. Driveways are subject to review by the Public Works Director.

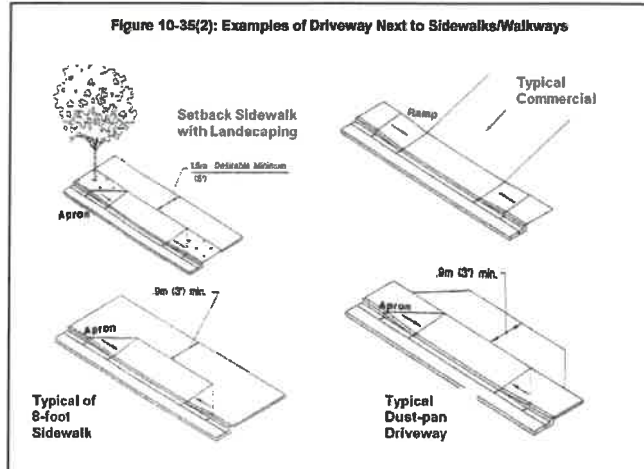

A driveway apron is not required or proposed for the alley access. The driveway apron and alley access at the intersection of 7th Street is proposed to be improved to City and ADA accessibility standards with approval from the Public Works Director.

10-35-2-13: Vertical Clearances: Driveways, private streets, aisles, turn-around areas and ramps shall have a minimum vertical clearance of 13' 6" for their entire length and width.

10-35-2-14: VISION CLEARANCE: No visual obstruction (e.g., sign, structure, solid fence, or shrub vegetation) shall block the area between two and one-half feet (2 ½') and eight (8) feet in height in "vision clearance areas" on streets, driveways, alleys, mid-block lanes, or multi-use paths where no traffic control stop sign or signal is provided, as shown in Figure 10-35(4). The following requirements shall apply in all zoning districts:

- B. At the intersection of an alley or driveway and a street, the minimum vision clearance shall be ten feet (10').

The sides of the minimum vision clearance triangle are the curb line or, where no curb exists, the edge of pavement. Vision clearance requirements may be modified by the Public Works Director upon finding that more or less sight distance is required (i.e., due to traffic speeds, roadway alignment, etc.). This standard does not apply to light standards, utility poles, trees trunks and similar objects. Refer to Section 10-1-4 of this Title for definition.

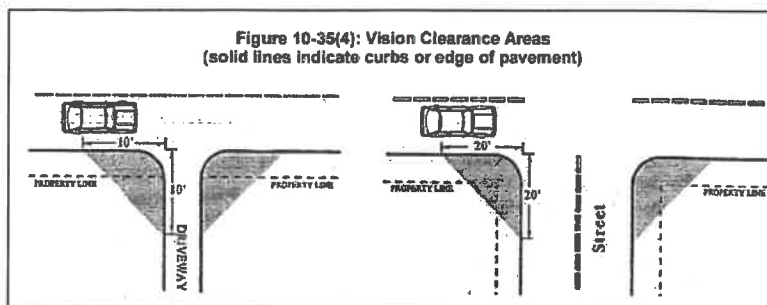

No fencing, structures, or landscaping are proposed that are anticipated to impact vision clearance on this site. The applicant shall maintain the 10' vision clearance area on either side of the alley to maintain vision clearance for vehicle and pedestrian safety. The variance for the front yard setback does not supersede this requirement for vision clearance (Condition 9.1). This criterion is met or is conditioned to be met.

10-35-3-1: SIDEWALK REQUIREMENTS:

- A. Requirements: Sidewalks shall be newly constructed or brought up to current standards concurrently with development under any of the following conditions:**
 - 1. Upon any new development of property.**

There are currently no sidewalks on the street frontage of the subject site. In accordance with this property development sidewalks shall be installed along the street frontage of Tax Lot 5602 (the tax lot where the dwelling and carport are proposed to be sited). No development is proposed on Lot 5601 as part of this application, only siting of the temporary construction site dwelling. Therefore, sidewalks are not required to be constructed along the Lot 5601 street frontage. Sidewalks shall be installed along the Lot 5602 street frontage prior to issuance of a Certificate of Occupancy. A work in the ROW permit shall be obtained prior to beginning any work in the ROW (Condition 9.2). This criterion is met or is conditioned to be met.

- B. Exceptions: The Public Works Director may issue a permit and certificate allowing noncompliance with the provisions of subsection (A) of this section and obtain instead a nonremonstrance agreement for future improvements when, in the Public Works Director’s determination, the construction of a sidewalk is impractical for one or more of the following reasons:**
 - 1. Sidewalk grades have not and cannot be established for the property in question within a reasonable period of time.**
 - 2. Future installation of public utilities or street paving would, of necessity, cause severe damage to existing sidewalks.**
 - 3. Topography or contours make the construction of a sidewalk impractical.**
 - 4. Physical improvements are present along the existing street that prevents a reasonable installation within the right-of-way or adjacent property.**
 - 5. If the proposed development is in a residential zoning district and there are no sidewalks within 400 linear feet.**
- C. Appeals: If the owner, builder or contractor considers any of the requirements impractical for any reason, s/he may appeal the decision to the Planning Commission.**
- D. Timing: Sidewalks shall be constructed and approved by the Public Works Department prior to final inspection for the associated building permit. No certificate of occupancy may be issued until the required sidewalks are constructed or financially secured.**

The construction of sidewalks is required prior to the issuance of a Certificate of Occupancy as previously discussed and conditioned.

TITLE 10: CHAPTER 36: PUBLIC FACILITIES

10-36-2-7: Alleys, Public or Private: Alleys shall provide a 20-foot right-of-way and 16 feet of pavement. Unless otherwise approved by the Planning Commission, where topographical conditions will not reasonably permit, grades shall not exceed twelve percent (12%) on alleys. Alley intersections and sharp changes in alignment shall be avoided. The corners of necessary alley intersections shall have a radius of not less than twelve (12) feet or wider if required by the Fire District.

The subject site will take access from an existing paved alley. This alley is 20 feet wide with approximately 16 feet wide pavement. The alley is primarily flat and does not reach grades near or above 12%. The fire department did not respond with referral comments requiring modifications to either the alley or alley access. The alley is determined to be adequate as is, with the exception of the improvements to the alley/7th Street intersection that have previously been conditioned. These criteria are met.

10-36-2-16: Sidewalks, Planter Strips, Bicycle Lanes: Sidewalks, planter strips, and bicycle lanes shall be installed in conformance with applicable provisions of the Florence Transportation System Plan, Comprehensive Plan, adopted street plans, City of Florence Standards and Specifications and the following standards:

- A. Sidewalks may be placed adjacent to the street or at the property line with planter strips where practicable, or as otherwise directed by the Public Works Director.**
- B. In areas with high pedestrian volumes, the City may approve a minimum 12-foot wide sidewalk area, curb tight, with street trees in tree wells and / or landscape planters.**
- C. Bicycle lanes shall be constructed on all newly constructed arterial and collector streets as well as all arterial and collector streets that are widened to provide additional vehicular capacity, as indicated in the TSP, unless otherwise designated.**
- D. Sidewalks shall be provided on both sides of the street for all arterial and collector streets. Sidewalks shall be provided on at least one side of the street for local streets. Exceptions may be granted if the City determines that hillsides, drainage facilities, ditches, waters of the state, or natural landscapes are to be preserved, then sidewalks on one side or a multi-use path may be approved. Sidewalks are not required on T-courts (hammer-head).**
- E. Where practical, sidewalks shall be allowed to meander around existing trees if in conformance with the requirements of the Americans with Disabilities Act. F. Maintenance of sidewalks and planter strips in the right-of-way is the continuing obligation of the adjacent property owner.**

The sidewalks installed along the street frontage of Lot 5602 shall be built to City standards and in accordance with this code section with a right-of-way permit applied for and plan approved by the City of Florence Public Works Director (Condition 9.2). This criterion is conditioned to be met

10-36-2-17: Existing Rights-of-Way: Whenever existing rights-of-way adjacent to or within a proposed development are developed less than standard width, additional rights-of-way

shall be provided at the time of subdivision or site development, in conformance with FCC 10-36-2-5.

The existing ROW adjacent to the subject site is the 7th Street ROW and is platted at 66 feet in width. In accordance with FCC 10-36-2-5 a typical local street section width is 60 feet. The 7th street ROW adjacent to the subject property with within City standards for width. This criterion is met.

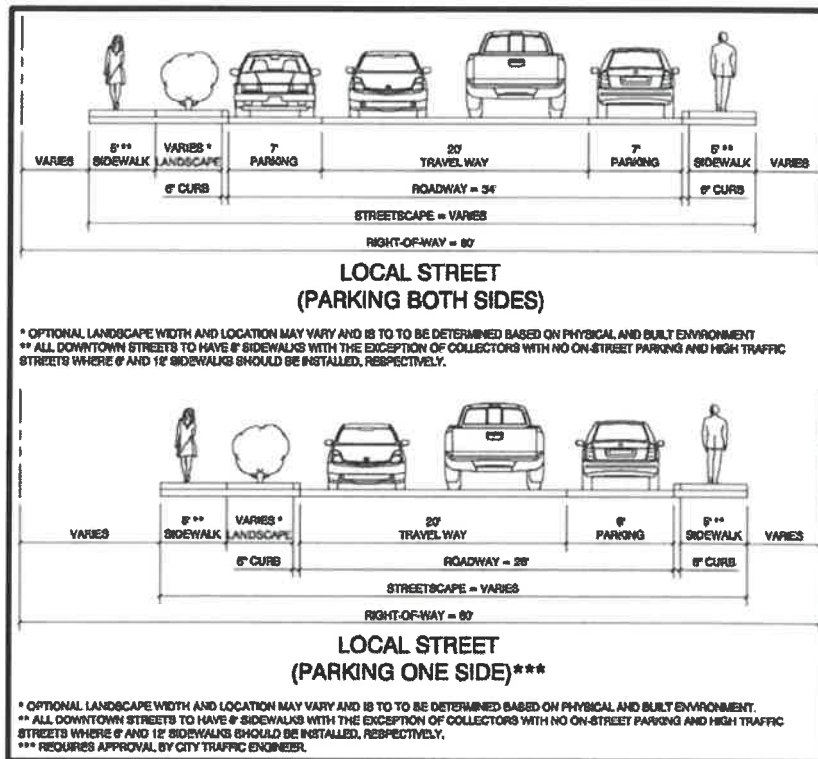

10-36-2-18: Curbs, Curb Cuts, Ramps, and Driveway Approaches: Concrete curbs, curb cuts, curb ramps, bicycle ramps and driveway approaches shall be constructed in accordance with Chapter 35, Access and Circulation, City of Florence Standards and Specifications and the following standards:

- A. Curb exposure shall be per City Standards and Specifications.
- B. There shall be no curbs on alleys unless otherwise approved by the Public Works Director.
- C. Curb extensions (bulb-outs) at local residential street intersections are optional. If provided, the minimum width between the curb extensions shall be 24-feet, unless otherwise approved by the Public Works Director. Curb extensions shall not be used on streets with bike lanes.

The subject site proposes access from the existing alley. As previously discussed, the curb cut at the alley/ROW intersection shall be developed to City and applicable ADA standards with plans approved by the City of Florence Public Works Department (Condition 10.1). Section B above states that the alley will have no curbs. These criteria are conditioned to be met.

10-36-2-22: Mail Boxes: Plans for mail boxes shall be approved by the United States Postal Service

The applicant shall have approval from the USPS for the location of a mailbox on site (Condition 10.2). This criterion is conditioned to be met.

10-36-3: SANITARY SEWERS, WATER, STORMWATER, AND FIRE PROTECTION:

- A. Sewers, Water, and Stormwater Mains Required: Sanitary sewers, water mains, and stormwater drainage shall be installed to serve each new development and to connect developments to existing mains in accordance with the City’s Wastewater Master Plan, Water System Master Plan, and Stormwater Master Plan, Florence Code Title 9 Chapters 2, 3’ and 5, and the applicable construction specifications. When streets are required to be stubbed to the edge of the subdivision; stormwater, sewer and water system improvements shall also be stubbed to the edge of the subdivision for future development.**
- B. Sewer, Water, and Stormwater Plan Approval: Development permits for stormwater drainage, sewer and water improvements shall not be issued until the Public Works Director or their designee has approved all stormwater, sanitary sewer and water plans in conformance with City standards, and Florence Code Title 9 Chapters 2, 3 and 5.**
- C. Existing Watercourse: Where a proposed development is traversed by a watercourse, drainage way, channel, or stream, there shall be provided a storm water easement or drainage right-of-way conforming substantially to the lines of such watercourse and such further width as will be adequate for conveyance and maintenance to protect the public health and safety and consistency with the Stormwater Manual.**
- D. Over-Sizing: The City may require as a condition of development approval that sewer, water, and/or storm drainage systems serving new development be sized to accommodate future development within the area as projected by the applicable Water, Sewer, and/or Storm Drainage Master Plan, and Florence Code Title 9 Chapter 1. The developer may be entitled to credit or reimbursement for over-sizing City master planned improvements.**
- E. Fire Protection: All new development shall conform to the applicable provisions of the Oregon Fire Code. Developers shall provide verification of existing and proposed water service mains and hydrant flow supporting the development site. Fire flow analyses and plans for hydrants and water service mains shall be subject to review and approval by the Building Official or Fire Marshal.**
- F. Inadequate Facilities: Development permits may be restricted by the City where a deficiency exists in the existing water, sewer or stormwater system that cannot be rectified by the development and that if not rectified will result in a threat to public health or safety, surcharging of existing mains, or violations of state or federal standards pertaining to operation of domestic water and sewerage treatment systems. 10-36-4: EROSION CONTROL: In addition to standard City requirements for stormwater, erosion control and sand management, projects that disturb one (1) or more acres of land over a period of time, a National Pollution Discharge**

Elimination System (NPDES) Permit must be obtained from the Department of Environmental Quality prior to the issuance of a development permit or land use permit based on appropriate criteria.

According to the referral comments from the City Public Works Department, the subject site has access to adequate utilities to support the proposed development of the detached SUD. This criterion is met.

10-36-5: UTILITIES:

A. Underground Utilities:

- 1. Generally. All new utility lines including, but not limited to, those required for electric, communication, lighting, and cable television services and related facilities shall be placed underground, except for temporary utility service facilities during construction, and high capacity electric lines operating at 50,000 volts or above.**
- 2. Subdivisions. In order to facilitate underground placement of utilities:**
 - a. The developer shall make all necessary arrangements with the serving utility to provide the underground services. Care shall be taken to ensure that all above ground equipment does not obstruct vision clearance areas for vehicular traffic.**
 - b. The City reserves the right to approve the location of all surface-mounted facilities.**
 - c. All underground utilities, including water, sanitary sewers and storm drains installed in streets by the developer, shall be constructed prior to the surfacing of the streets.**
 - d. Stubs for service connections shall be long enough to avoid disturbing the street improvements when service connections are made.**

All utilities shall be placed underground in accordance with this Code section (Condition 10.3). This criterion is conditioned to be met.

C. Exception to Undergrounding Requirement: An exception to the undergrounding requirement may be granted due to physical constraints, such as steep topography, sensitive lands, or high water table or existing development conditions.

No such exemptions are present on this site. Therefore, utilities shall be placed underground (Condition 10.3). This criterion is conditioned to be met.

TITLE 10: CHAPTER 37: LIGHTING

10-37-5: EXEMPTIONS:

R. In addition to exceptions mentioned above the below apply to residential uses.

- 1. One partly shielded or unshielded luminaire at the main entry, not exceeding 630 lumens.**
- 2. Any other partly shielded or unshielded luminaires not exceeding 315 lumens.**
- 3. Low voltage landscape lighting aimed so that glare is not visible from adjacent properties and not exceeding 525 lumens per fixture.**
- 4. Shielded directional flood lighting aimed so that direct glare is not visible from adjacent properties and not exceeding 1,260 lumens.**
- 5. Lighting installed with a vacancy sensor, where the sensor extinguishes the lights no more than 10 minutes after the area is vacated.**
- 6. Decorative low wattage lights.**

This code section was provided as a reference to the exceptions allowed for residential units. As the residential unit is exempt from design review a lighting plan is not required at this time. Lighting fixtures shall be reviewed at the time of building permit review to ensure compliance with FCC 10-37 with the exception of lighting exempt from this Code chapter (Informational 8).

VII. CONCLUSION

The application meets the requirements of Florence City Code and the Florence Realization 2020 Comprehensive Plan with conditions as outlined in the resolution.

This application is for three items

1. CUP to allow a single-unit detached dwelling in the MSB zoning district.
2. Temporary construction site dwelling during construction of the single-unit detached dwelling and to be removed prior to issuance of Certificate of Occupancy.
3. Variance request for a decreased front yard setback of 5 feet to allow for a roof over the entrance porch
4. Variance request to decrease the rear yard setback from 10 feet to 5 feet.

VIII. EXHIBITS:

"A" Findings of Fact
"B" Land Use Application
"C" Site Plans

Exhibit H

From: [Jeremy Austin](#)
To: [Doug Adams - J&M Homes](#); [Planning Department](#)
Cc: [Marty Brown - J&M Homes](#)
Subject: RE: attn; Jeremy/Castleman
Date: Wednesday, April 24, 2024 4:00:44 PM
Attachments: [image001.png](#)
[image003.png](#)
[image004.png](#)

Hello Doug,

Can you provide the paperwork with the insulation values this is built to? This should be the only other item we need to get the plan review done.

Thank you

Jeremy



Jeremy Austin
Building Permit Technician
[City of Florence Building Department](#)
Phone: (541) 997-2141 Ext. 2
Email: Jeremy.austin@ci.florence.or.us
250 Highway 101, Florence, OR 97439

The City of Florence is an equal opportunity employer and service provider.

PUBLIC RECORDS LAW DISCLOSURE:

This email is a public record of the City of Florence and is subject to public inspection unless exempt from disclosure under Oregon Public Records Law. This email is also subject to the City's Public Records Retention Schedule.

From: Doug Adams - J&M Homes <dadams@jandmhomes.com>
Sent: Wednesday, April 24, 2024 8:46 AM
To: Jeremy Austin <jeremy.austin@ci.florence.or.us>; Planning Department <PlanningDepartment@ci.florence.or.us>
Cc: Marty Brown - J&M Homes <mbrown@jandmhomes.com>
Subject: RE: attn; Jeremy/Castleman

Sorry about that, here it is.

From: Jeremy Austin <jeremy.austin@ci.florence.or.us>
Sent: Tuesday, April 23, 2024 1:36 PM
To: Doug Adams - J&M Homes <dadams@jandmhomes.com>; Planning Department <PlanningDepartment@ci.florence.or.us>
Cc: Marty Brown - J&M Homes <mbrown@jandmhomes.com>
Subject: RE: attn; Jeremy/Castleman

Hello Doug,

We are still waiting for the plans. All we received was the MDI number, no floor plan was attached.

Thank you,

Jeremy



Jeremy Austin
Building Permit Technician
City of Florence Building Department
Phone: (541) 997-2141 Ext. 2
Email: Jeremy.austin@ci.florence.or.us
250 Highway 101, Florence, OR 97439

The City of Florence is an equal opportunity employer and service provider.

PUBLIC RECORDS LAW DISCLOSURE:

This email is a public record of the City of Florence and is subject to public inspection unless exempt from disclosure under Oregon Public Records Law. This email is also subject to the City's Public Records Retention Schedule.

From: Doug Adams - J&M Homes <dadams@jandmhomes.com>
Sent: Tuesday, April 23, 2024 12:33 PM
To: Planning Department <PlanningDepartment@ci.florence.or.us>
Cc: Marty Brown - J&M Homes <mbrown@jandmhomes.com>
Subject: attn; Jeremy/Castleman

Was there anything else you needed form me to move forward with Mr. Castleman's permits? Let me know if you need anything that I can supply, Doug



<mailto:dadams@JandMhomes.com>

Douglas Adams
J & M Homes

New Home Consultant
541-928-1471

From: [Doug Adams - J&M Homes](#)
To: [Clare Kurth](#)
Cc: [Marty Brown - J&M Homes](#)
Subject: RE: Attn: Clair Crus RE Castleman 15x52FW: 561m
Date: Friday, March 8, 2024 10:22:59 AM
Attachments: [image001.png](#)
[image002.png](#)
[image003.png](#)

I can get you the plan set you need I just need the exact size that has been chosen, Doug

From: Clare Kurth <clare.kurth@ci.florence.or.us>
Sent: Friday, March 8, 2024 10:12 AM
To: Doug Adams - J&M Homes <dadams@jandmhomes.com>
Cc: Marty Brown - J&M Homes <mbrown@jandmhomes.com>; Wendy Farley-Campbell <wendy.farleycampbell@ci.florence.or.us>; Jeremy Austin <jeremy.austin@ci.florence.or.us>
Subject: RE: Attn: Clair Crus RE Castleman 15x52FW: 561m

When we get the complete plan set on the unit, we will call Bud in and have him complete the manufactured home permits applications. Hopefully this can get installed and meet the May 25th deadline required by the conditional use permit.

Have a great weekend,

Clare K

From: Doug Adams - J&M Homes <dadams@jandmhomes.com>
Sent: Friday, March 8, 2024 9:41 AM
To: Clare Kurth <clare.kurth@ci.florence.or.us>
Cc: Marty Brown - J&M Homes <mbrown@jandmhomes.com>; Wendy Farley-Campbell <wendy.farleycampbell@ci.florence.or.us>
Subject: RE: Attn: Clair Crus RE Castleman 15x52FW: 561m

Ok, great. Thanks!

From: Clare Kurth <clare.kurth@ci.florence.or.us>
Sent: Friday, March 8, 2024 9:27 AM
To: Doug Adams - J&M Homes <dadams@jandmhomes.com>
Cc: Marty Brown - J&M Homes <mbrown@jandmhomes.com>; Wendy Farley-Campbell <wendy.farleycampbell@ci.florence.or.us>
Subject: RE: Attn: Clair Crus RE Castleman 15x52FW: 561m

Oh good! I was worried. Either the 15 x 50 or the 15 x 48 will fit on the lot. Whichever is the best fit for Bud Castleman is fine.

Clare K

From: Doug Adams - J&M Homes <dadams@jandmhomes.com>
Sent: Friday, March 8, 2024 8:32 AM
To: Clare Kurth <clare.kurth@ci.florence.or.us>
Cc: Marty Brown - J&M Homes <mbrown@jandmhomes.com>
Subject: RE: Attn: Clair Crus RE Castleman 15x52FW: 561m

I apologize I sent the wrong plan, we had spoken about a 15x50 but if it needs to be 15x48 we can do that as well

From: Clare Kurth <clare.kurth@ci.florence.or.us>
Sent: Thursday, March 7, 2024 5:04 PM
To: Doug Adams - J&M Homes <dadams@jandmhomes.com>; Planning Department <PlanningDepartment@ci.florence.or.us>
Cc: Marty Brown - J&M Homes <mbrown@jandmhomes.com>
Subject: RE: Attn: Clair Crus RE Castleman 15x52FW: 561m

Doug,

Thank you for sending these plans. Unfortunately, the plan appears to be for a 56 foot long unit and this design will not fit on Bud Castleman's lot in a way that is compliant with the zoning district and his conditional use permit. His maximum allowed foot print for the dwelling unit is 15x50. The lot is 60 feet in length and requires a minimum 5-foot side yard setback on the east and west property lines.

When I talked with him last week it sounded like he had a 15x48 foot site plan picked out.

The attached site plan is a little rough, but is what was submitted and approved by Planning Commission. He owns both parcels on the snip below, but only has approval to develop Parcel 2 on the right (tax lot 5602).

7th STREET
66' PUBLIC RIGHT OF WAY

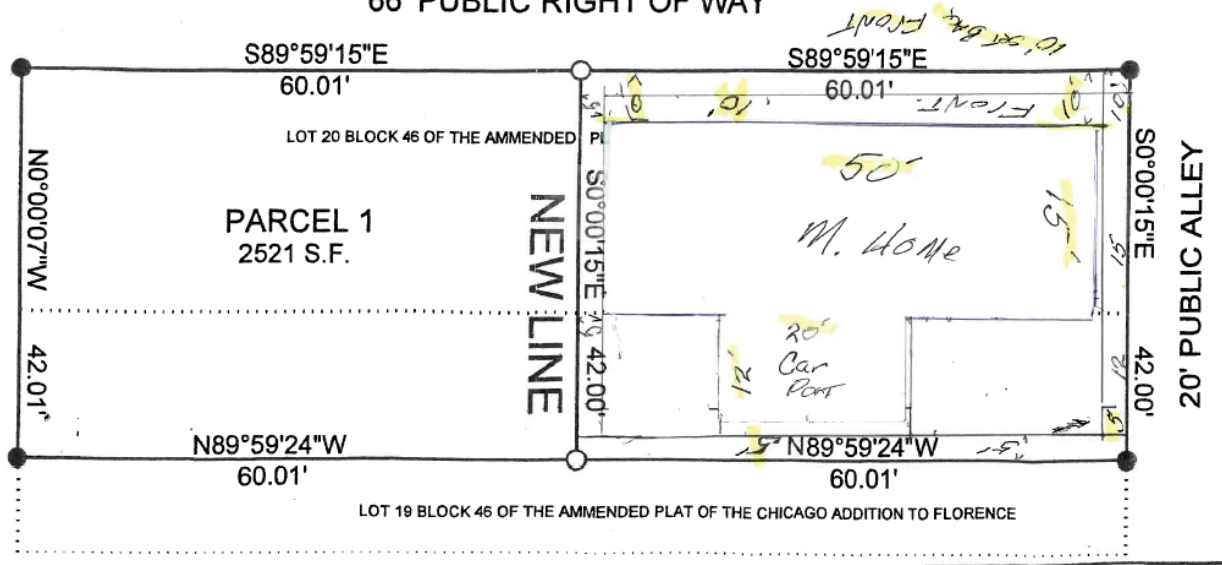

Clare Kurth, AICP Candidate
Associate Planner | City of Florence
clare.kurth@ci.florence.or.us

City of Florence
250 Hwy 101
Florence, OR 97439

Follow Us! [City Website](#) | [Facebook](#) | [Twitter](#) | [Instagram](#) | [Vimeo](#)

From: Doug Adams - J&M Homes <dadams@jandmhomes.com>
Sent: Thursday, March 7, 2024 3:49 PM
To: Planning Department <PlanningDepartment@ci.florence.or.us>
Cc: Marty Brown - J&M Homes <mbrown@jandmhomes.com>
Subject: Attn: Clair Crus RE Castleman 15x52FW: 561m

From: Darby, Haily <Haily.Darby@GoldenWestHomes.com>
Sent: Thursday, March 7, 2024 3:34 PM
To: Doug Adams - J&M Homes <dadams@jandmhomes.com>
Cc: Marty Brown - J&M Homes <mbrown@jandmhomes.com>
Subject: RE: 561m

From: Doug Adams - J&M Homes <dadams@jandmhomes.com>
Sent: Thursday, February 29, 2024 3:08 PM
To: Darby, Haily <Haily.Darby@GoldenWestHomes.com>

Cc: mbrown <mbrown@jandmhomes.com>

Subject: [EXTERNAL] 561m

External email: careful w/ links or attachments

Could you do me a favor? I need a 561M floorplan showing a 15 wide stretch, could you generate that for me?



<mailto:dadams@JandMhomes.com>

Douglas Adams

J & M Homes

New Home Consultant

541-928-1471

CONFIDENTIALITY NOTICE

This message and the accompanying documents contain information that belongs to the sender and may contain information that is privileged, confidential, or exempt from disclosure under applicable law. If the reader of this e-mail is not the intended recipient, you are hereby notified that you are strictly prohibited from reading, disseminating, distributing, copying, or taking action in reliance on the content of this communication. If you have received this e-mail in error, please notify the sender immediately and destroy the original transmission. Thank you.

To view our privacy policies, please visit <https://www.claytonhomes.com/privacy/>